

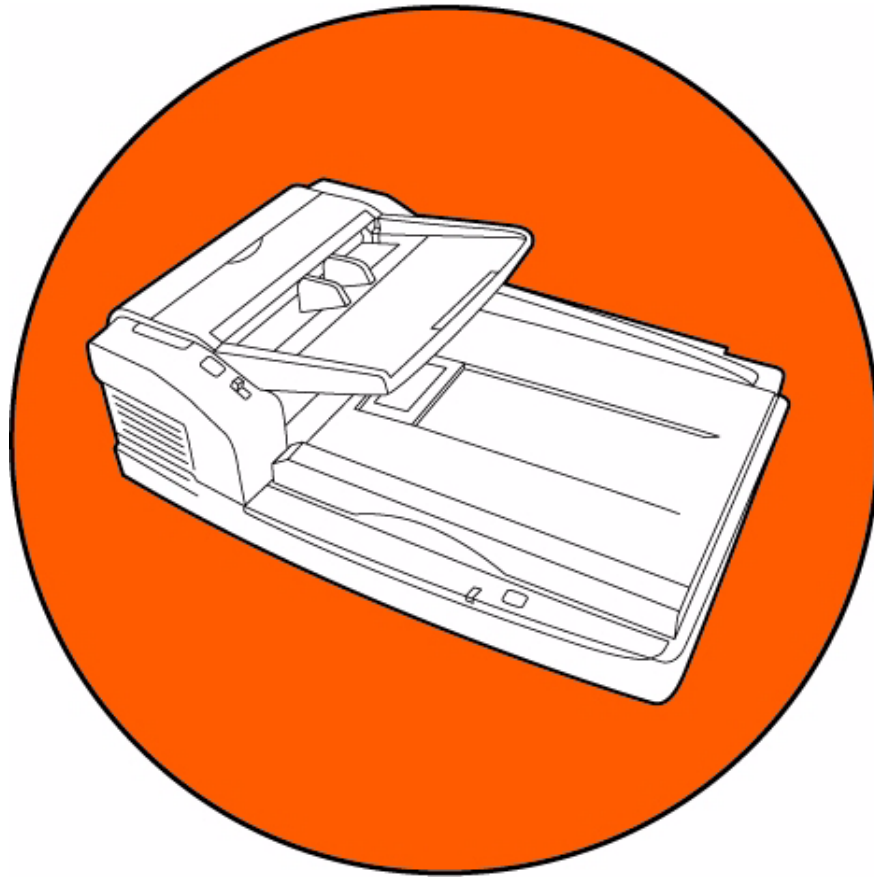

Trüper Operator Manual



trüper[™]
3200

Color Scanner

Part Number S006050 Rev. B

Böwe Bell + Howell Scanners

Please read this manual for information about the proper installation, operation and maintenance of the scanner. Keep this documentation in a safe place for future reference.

Disclaimer

The instructions and descriptions contained in this document were accurate at the time of publishing. However, succeeding products and documents are subject to change without notice. Therefore, Bowe Bell + Howell Scanners, L.L.C. assumes no liability for damages incurred directly or indirectly from errors, omissions, or discrepancies between the product and this document.

© 2005 Bowe Bell + Howell Scanners, L.L.C. All rights reserved. All material in this publication is confidential and is to be used by and distributed to authorized personnel of the purchaser only. All intellectual property rights remain the property of Bowe Bell + Howell Scanners, L.L.C. No part of this publication may be reproduced, distributed, modified, displayed, transmitted, stored in a retrieval system, or translated into any human or computer language, in any form or by any means, electronic, mechanical, magnetic, optical, chemical, manual, or otherwise, without the prior written permission of the copyright owner, Bowe Bell + Howell Scanners, L.L.C., 760 South Wolf Road, Wheeling, IL 60090-6232, USA.

© **Bowe Bell + Howell Scanners, L.L.C.**
760 South Wolf Road
Wheeling, IL 60090-6232, USA

Corporate Offices: 1-847-675-7600

Sales: 1-800-SCAN-494

Technical Support: 1-800-SCAN-495

1-416-760-4499

FAX 1-847-423-3047

TTY Line: 1-847-423-3032

Internet: www.bbhscanners.com

The information given in this *Operator Manual* is subject to change without notice. Please go to www.bbhscanners.com to download the most current manual.



International Offices

In Europe

The Bowe House
The Sterling Centre - Bracknell
Berkshire RG12 2PW
United Kingdom
Telephone: +44-1344-462-103
Fax: +44-1344-462-101
Technical Support:
Engsupport.scanner@bowebellhowell.com

In Asia: China

No. 2 room, 601 Tower W3, Oriental Plaza
No. 1 East Chang An Ave, Dong Cheng Dist.
Beijing, 100738
China (PRC)
Telephone (86) 10 85181839
Fax +86-10-85181839

Trademark Acknowledgments

ENERGY STAR® and the ENERGY STAR certification mark are registered U.S. marks.

Windows® 2000 is Microsoft® Windows® 2000 operating system.

Windows® XP is Microsoft® Windows® XP operating system.

Microsoft® and Windows® are either registered trademarks or trademarks of Microsoft Corporation in the United States and/or other countries.

VirtualReScan®, Kofax® and ImageControls® are registered trademarks of Kofax Image Products.

ISIS® and PixTools® are registered trademarks of Pixel Translations, a division of Captiva Software Corporation.

Adobe®, Acrobat® and Reader® are registered trademarks of Adobe Systems Incorporated.

Pentium® is a registered trademark of Intel Corporation.

USB™ is a registered trademark of the USB Implementers Forum.

Trüper™ is a registered trademark of Böwe Bell + Howell Scanners, L.L.C.

All other product names and logos mentioned herein are the property of their respective companies.



Web Site: www.bbhscanners.com

© 2005 Bowe Bell + Howell Scanners, L.L.C

Table of Contents

Trademark Acknowledgments	4
Federal Communications Commission Requirements	8
Thank You	9
About Trüper	9
About This Manual	9
Specifications	10
Scanner Unit	10
Advanced Features	12
Consumable Parts List	13
Computer System Requirements	13
Component Identification	15
Minimum Space Requirements	17
Top View	17
Front View	17
Safety Precautions for the Operating Environment	18
The Scanner Unit	18
Power Source	23
Handling the CD-ROM	23
Installing the Scanner	25
Quick Installation Checklist	25
Unpacking the Scanner	26
Attaching the Feeder Tray	27
Initial Setup and Installation	28
Connecting the Scanner	28
Installing the Windows Scanner Driver	29
Trüper Software Installation	34
Installing the Software	34
View Manuals	49
Contents of the Installation Resource CD-ROM	49
Operating the Scanner	50
Turning on the Scanner	50
LED Status Indicator	51
Document Preparation	52
General Guidelines	52
Guidelines for Using the ADF	52
Types of Documents to Avoid in the ADF	54
Using the Trüper ADF	55
Clearing Paper Jams in the ADF	59
Removing Paper Jams from the Document Feeder	59
Removing Paper Jams from the Exit Path	61
STOP/START Button Operation	63
Feed Modes with the ADF	64
Manual Feed	64
Wait for Start to Feed	65

Automatic Start to Feed	65
Scanner Manual Feed Setting	66
Feeding Speed	67
Detect Double Feed	68
Using the Flatbed	70
Scanning Thick Documents	73
Repeated Use of the Flatbed	73
Changing the Background Color	74
Changing the Background Color Reference Plates	74
Changing the Background Color with the Flatbed Sheet	76
Operator Maintenance	78
Cleaning the Outside of the Scanner	78
Cleaning Inside the Scanner	79
Roller Cleaning Paper	80
Cleaning the Paper Feed Roller, Separation Roller and Retard Roller	81
Cleaning the Drive Rollers and Free Rollers in the ADF	83
Cleaning the Drive Rollers, Free Rollers and Exit Rollers in the Exit Door	85
Cleaning the Background Color Reference Plates and ADF Glass	87
Cleaning the Paper Sensor, Waiting Sensors and Double Feed Detector	89
Cleaning the Starting, Skew and Ending Sensors	90
Cleaning the Flatbed Glass and Document Cover Detector	92
Replacing Consumables	94
Replacing the Paper Feed Roller Module	94
Replacing the Retard Roller Module	97
Trüper User Utility	100
Starting the User Utility	100
Functions and Settings	101
User Utility Main Dialog Window	101
Restoring Shading to the Default	105
Scanner Counter	106
Help	107
Select Scanner(X)	107
Save Info	107
Close	107
Check Version Information	108
Troubleshooting	109
User Utility Error Codes	109
Troubleshooting Scanner Operations	111
SCSI Interface Connection	114
Connecting the Scanner	114
SCSI ID Setting	115
Repacking Instructions	117
Glossary	118

Appendix 1—Front Page, Pre-Scan Imprinter Installation	120
Safety Precautions	120
Component Identification	121
Installing the Imprinter Unit	121
Ink Cartridge Installation and Printing Position	125
Safety Precautions	125
Installing the Ink Cartridge	125
Adjusting the Printing Position	127
Cleaning the Ink Cartridge	129
Cleaning the Print Head with the User Utility	129
Cleaning the Print Head Manually	129
Removing the Ink Cartridge	130
Ink Cartridge Specifications	131
Imprinter (Endorser)	132
Appendix 2—Multicolor Dropout (MCD) and Single Color Dropout	134
Single Color Dropout	134
Multicolor Dropout (MCD)	135
How to Determine RGB Value	140
Appendix 3—Shading Adjustment	141
About Shading Adjustment	141
What Is the Purpose of Shading Adjustment?	141
When Is Shading Adjustment Required?	141
Shading Adjustment Procedure	141
Appendix 4—Adding Memory	142
Recommended DIMM Specifications	142
Installing a DIMM Module	142
Removing the Interface Board	142
Installing a DIMM Module on the Interface Board	143
Re-installing the Interface Board	144
Index	145
Limited Use License Agreement	149

Federal Communications Commission Requirements

(For United States only)

This equipment has been tested and found to comply with the limits for a Class A digital device, pursuant to part 15 of the FCC Rules. These limits are designed to provide reasonable protection against harmful interference when the equipment is operated in a commercial environment. This equipment generates, uses and can radiate radio frequency energy and, if not installed and used in accordance with the instruction manual, may cause harmful interference to radio communications. Operation of this equipment in a residential area is likely to cause harmful interference in which case the user will be required to correct the interference at his own expense.

FCC Warning: To assure continued FCC compliance, the user must use only shielded interface cable and the provided power supply cord. Also, any unauthorized changes or modifications to this equipment would void the user's authority to operate this device.

(For Canada)

THIS CLASS A DIGITAL APPARATUS COMPLIES WITH CANADIAN ICES-003.

CET APPAREIL NUMÉRIQUE DE LA CLASSE A EST CONFORME À LA NORME NMB-003 DU CANADA.



Warning

- TO PREVENT FIRE OR SHOCK HAZARD, DO NOT EXPOSE THIS PRODUCT TO RAIN OR ANY TYPE OF MOISTURE.
- THE ELECTRICAL OUTLET MUST BE NEAR THIS EQUIPMENT AND MUST BE EASILY ACCESSIBLE.
- THIS PRODUCT SHOULD BE USED ONLY WITH THE POWER CORD THAT IS SUPPLIED WITH THE SCANNER OR WITH A POWER CORD THAT HAS BEEN APPROVED BY A CERTIFIED ELECTRICAL CONTRACTOR.



As an ENERGY STAR Partner, Bowe Bell + Howell Scanners, L.L.C. has determined that this product meets the ENERGY STAR guidelines for energy efficiency.

Thank You

Thank you for purchasing a Böwe Bell + Howell Trüper™ Color Scanner Model 3200. This is an exceptional, fast-scanning and ready-for-duty scanner.

The Trüper bundle consists of everything you need to connect and operate the scanner. This includes the scanner itself, a USB 2.0 cable and VirtualReScan (VRS) image enhancement software technology.

Trüper scanners are designed to be reliable, easy to connect and easy to maintain. They are also designed to handle a variety of document sizes and types.

Please take a few minutes to review this *Operator Manual*. It contains the detailed information you need to get the most out of your Trüper scanner.

Please register your new scanner. Registering serves as a verification of ownership and confirms your right to protection under the terms and conditions of your warranty. Registration also helps us serve you better if you need to call us about this product. Visit the [warranty registration](#) page on our web site or complete and return the warranty registration card that shipped with this product.

About Trüper

Your Trüper scanner offers the following features:

- Simplex and duplex scanning
- Flatbed scanning for exception documents
- Ultrasonic multifeed detection
- Black and white, grayscale and color scanning
- Automatic document feeder that holds up to 200 sheets
- VRS technology for exceptional image quality
- USB 2.0 connectivity

About This Manual

This manual contains information about the installation, operation and maintenance of the Trüper scanner. Please read this manual before installing or operating the unit. Keep the enclosed Trüper Installation Resource CD-ROM in the protective case and store it in a safe place for future reference. (For instructions for handling the CD-ROM, see [“Handling the CD-ROM” on page 23.](#)) The following symbols appear in the manual to alert you to important safety precautions and additional operating information:



Warning and **Caution** sections provide important information that you must be aware of to avoid injury to yourself and to avoid damage to the scanner and its components.



The **Do Not** symbol alerts you to actions that must be avoided for your safety and to extend the life of the scanner and its components.



Note paragraphs provide supplemental information about the features and use of the scanner, as well as tips for using the scanner effectively.

Specifications

Scanner Unit

This table describes the features directly related to the Trüper scanner functionality. These features include scanning speeds, document sizes, image quality and other hardware related characteristics.

Specification		Trüper Specification	
Scanning Mode		Duplex	
Scanning Method		Direct CCD ¹ (charge coupled device), Xenon Lamps	
Scanning Speed ² Letter Size Portrait	Binary 200 dpi	Simplex 62 ppm (pages per minute) Duplex 106 ipm (images per minute)	
	Color 150 dpi	Simplex 62 ppm Duplex 106 ipm	
Resolution (Flatbed or ADF)		Binary or Grayscale: 100-600 dpi (dots per inch) Color (with VRS): 100-400 dpi Optical: 600 dpi	
Output Options		Bitonal, Grayscale (8 bit) and Color (24 bit)	
Image Enhancement		 Auto Cropping, Deskew, Auto Brightness, Contrast Control, Auto Color Detect, Auto Rotation and Blank Page Deletion, Bar Code Recognition	
Document Size	Flatbed	Approx. 11.7 x 17 in. (297 x 432 mm)	
	ADF ³	Scanning size: Approx. 1.9 x 2.8 in. (48 x 70 mm) to 11.9 x 25 in. (302 x 635 mm)	
Paper Thickness (ADF)		2.0 to 5.9 mils (0.05 to 0.15 mm) Note: 1 mil = 1/1000 in.	
Paper Weight (ADF)		10.6 to 34 lbs. (40 to 127 g/m ²)	
Feeder Capacity		200 sheets of 17 lbs. (64 g/m ²) paper	
Scanner Size		30 x 20 x 11.4 in. (76 x 51 x 29 cm) Note: When the Document Cover is open, height is 22 in. (56 cm)	
Scanner Weight		64 lbs. (29 kg)	
Interface		USB 2.0 enhanced (cable included) or SCSI III	
Power Requirements		AC 100–120 V, 50/60 Hz	AC 220–240 V, 50/60 Hz
Power Consumption	Maximum (Scanning)	1.5 A	0.7 A
	Minimum (Standby)	0.6 A	0.3 A
	Sleep Mode	8 W	8 W

1. CCD components configured in a traditional CIS array.
2. The scanning speeds indicated in the specifications table were developed in a test environment. Actual speeds will vary depending on the computer memory, operating system and the scanning or document management software application.
3. The ADF supports sheets of paper up to 25 inches (635 mm) in length. For scanning paper longer than 14 inch (356 mm) legal size, a resolution of less than 300 dpi and single sheet feeding is recommended.

Specification		Trüper Specification
Environment	Operating Temperature and Humidity	59°F to 86°F (15°C to 30°C), 30% to 80% RH
	Storage Temperature and Humidity	32°F to 95°F (0°C to 35°C), 10% to 80% RH
Daily Duty Cycle		10,000 pages
Additional Features		End User Replaceable Feeder Rollers, Electronic Color Dropout (Red, Green, Blue), Switchable Background, Ultrasonic Multifeed, Scan Time Bar Code Recognition
Additional Contents		Power Cord, USB Cable, Roller Cleaning Kit, CD-ROM (Operator Manual, VRS, User Utility Software), Printed Documents (Quick Installation Checklist)
Bundled Software		VCDemo, QuickScan Pro Demo Software
Consumables Options		See the "Consumable Parts List" on page 13
Imprinter Options		Pre-Scan, Front Page
	Number of Characters	VCDemo 62 characters, QuickScan 72 characters
		The numbers of characters will vary according to the application

Advanced Features

The Trüper scanner boasts a broad feature set that complements a robust hardware platform. These advanced features enhance the scanner's ability to provide clean, crisp images. Kofax VirtualReScan Plus (VRS 4.0) enables many of these features. Other features are part of the scanner driver.

The following list provides a brief description of some of the more unique advanced features of Trüper. Additional information about these features can be found in other sections of this or other included manuals on your Trüper Installation Resource CD-ROM.

Auto Color Detect - This feature automatically identifies color documents from bitonal documents while scanning is in process. Auto Color Detect helps reduce document preparation of mixed batches that contain both color and bitonal images. Please refer to the VRS manual on your Trüper Installation Resource CD-ROM.

Auto Orientation - This feature automatically rotates a page that is scanned in a non-standard orientation. There is no need to perform manual rotation on each image after scanning. Auto Orientation eliminates the need to pre-sort batches of documents to ensure they are facing the same direction. Please refer to the VRS manual on your Trüper Installation Resource CD-ROM.

Bar Code Recognition - This image filter recognizes the bar codes in the scanned images. Refer to the application's operating manual for how to use the bar code.

Blank Page Deletion - This feature detects and deletes blank pages based on content. Blank Page Deletion is intended for batch scanning in Duplex mode. Please refer to the VRS manual on your Trüper Installation Resource CD-ROM.

Background Saturation - Use this feature when scanning documents with color backgrounds. Saturating or "smoothing" a document image changes the document background into one uniform color. "Smoothing" refers to the automated process of creating a fixed, uniform background. This process removes both scanning and paper non-uniformity and will allow the image to be compressed more effectively. Please refer to the VRS manual on your Trüper Installation Resource CD-ROM.

Multicolor Dropout - This feature removes specific and multiple colors from an image. Multicolor Dropout can be used in simplex and duplex scanning with independent colors dropped out on either side. Please refer to Appendix 2 - Multicolor Dropout (MCD) and Single Color Dropout sections of this manual (starting on [page 134](#)).

Double Feed Recovery - This feature detects the double feeding of documents and allows the operator to correct the missed documents without stopping the scanning application. Without Double Feed Recovery, the scanner operator may have to rescan the entire batch.

Consumable Parts List

Consumable parts are available from the Böwe Bell + Howell Scanning Essentials online store at <http://webstore.bbhscanners.com> or from the reseller where you purchased the Trüper scanner.

Part Number	Description
S005504	Roller Cleaning Kit
S006043	Roller Exchange Kit
0123030	Imprinter Unit
S005506	Imprinter Ink Cartridge
S006047	Shading Paper
S006049	Blower Accessory

Computer System Requirements

Item	PC Requirements
CPU	Minimum: Pentium 4, 2.4 GHz Recommended: Pentium 4, 3.0 GHz or higher
Memory	Black & white scanning: Minimum: 256 MB Recommended: 512 MB or higher for improved scanning speed Color scanning: Minimum: 512 MB Recommended: 1 GB or higher for improved scanning speed
OS	Windows 2000 Windows XP Professional Windows XP Home Edition
Display	Resolution 1024 x 768 or more; 65,536 colors or more
Interface	USB 2.0 (enhanced) SCSI (see “SCSI Interface Connection” on page 114)

Note

Please note the following recommendations and guidelines:

- Do not connect the scanner to a USB hub. A hub connection is not guaranteed to work.
- One GB or more of free space is required on the hard drive.

- Depending on the computer system and the scanning or document management software application used, you may not be able to scan a large color image in high resolution.
- The scanning speed will vary depending on the computer memory, CPU operating system and the scanning or document management software application used.
- Connecting the scanner with another SCSI device in a daisy chain is NOT RECOMMENDED.

For additional system requirements, please consult the user manual for your scanning or document management software application.

Component Identification

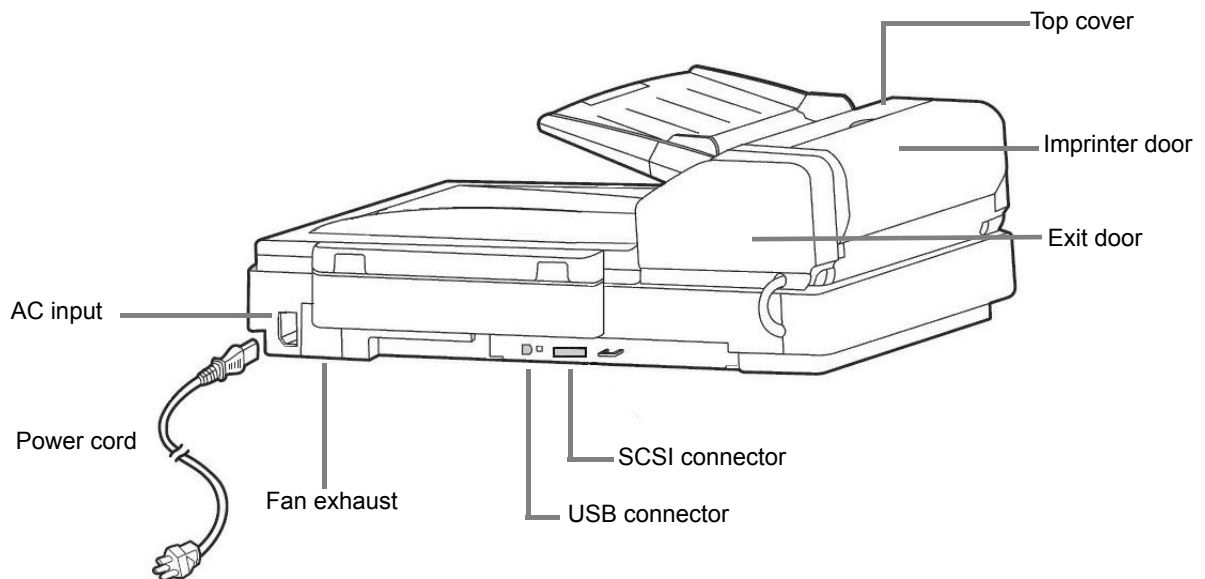
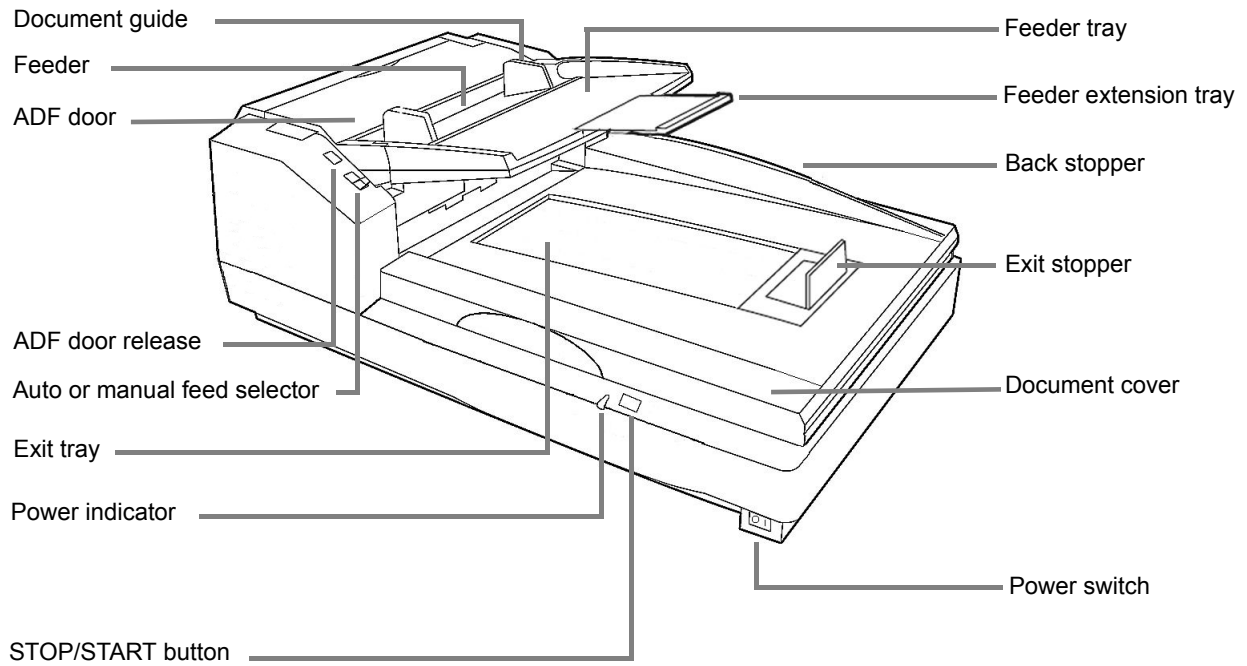

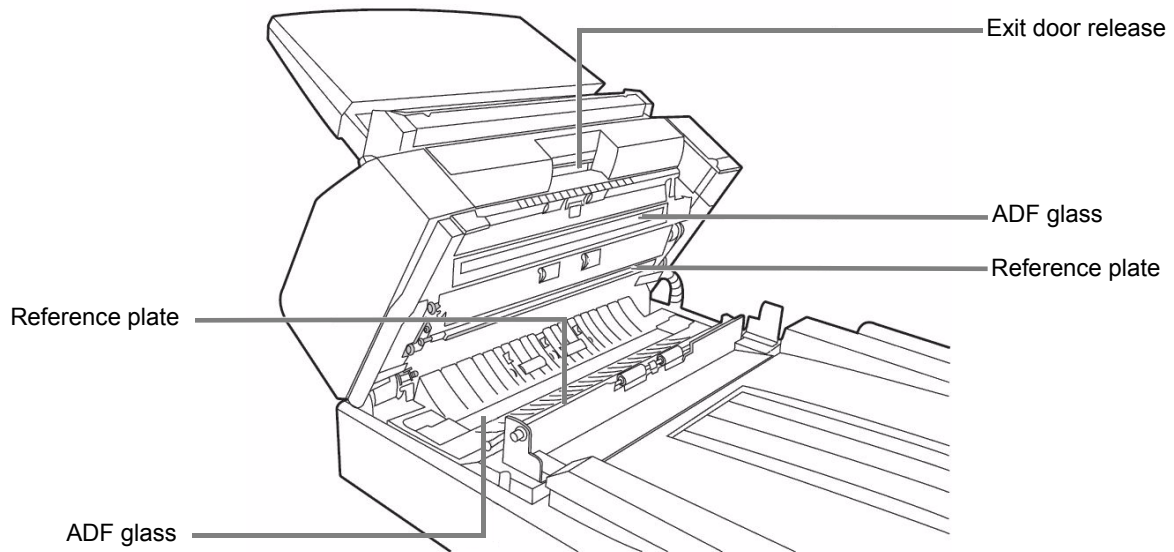
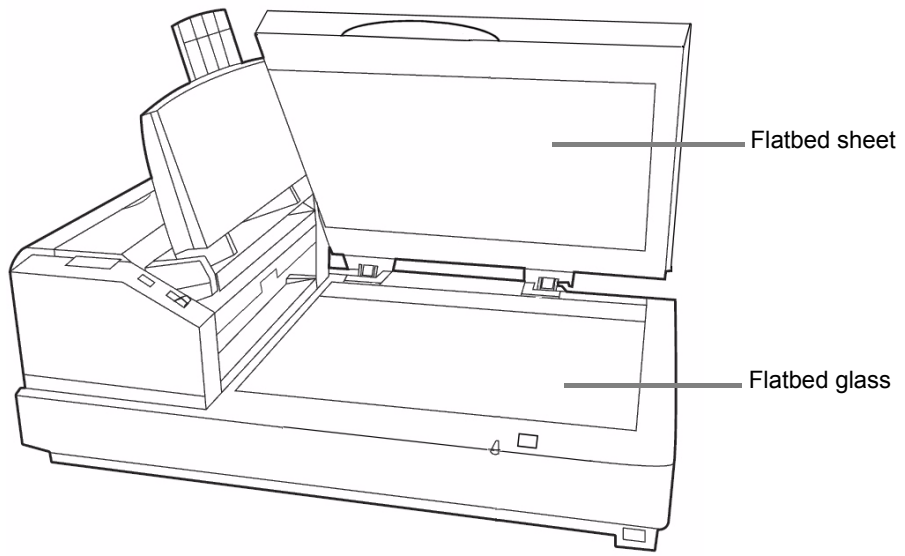

Minimum Space Requirements

Be sure to maintain the recommended area of open space around the top and sides of the scanner as shown in the following diagrams. This will allow you to use all of the features of the scanner and will assure that there is proper ventilation for the unit.

Top View

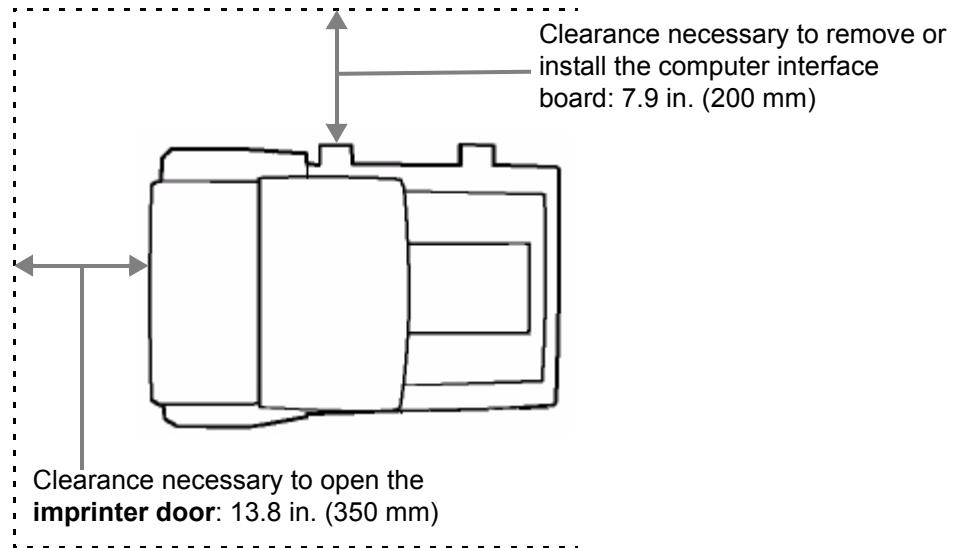

Front View

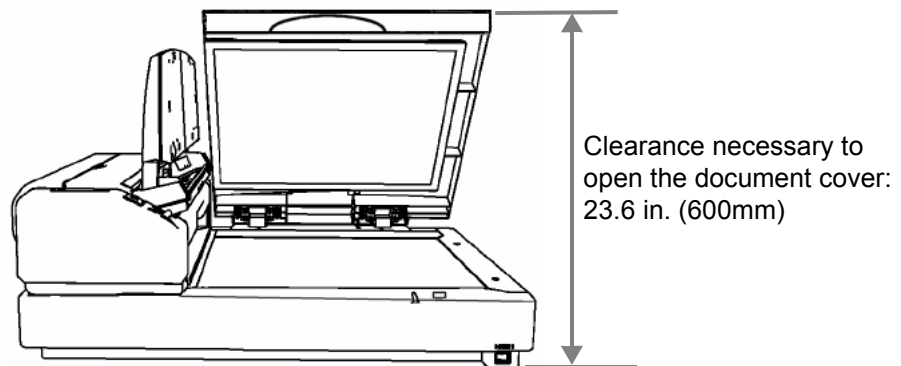

Safety Precautions for the Operating Environment

The Scanner Unit

The following safety precautions and proper handling instructions are recommended for your safety and to extend the life of the scanner:



Caution

Prior to scanning with the Automatic Document Feeder (ADF), remove all staples and paper clips from the sheets that you want to scan.

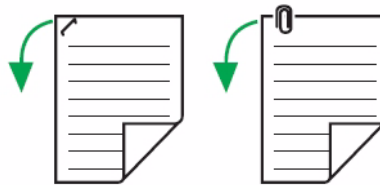

Do not disassemble the scanner. This will void your warranty. If there is a need to disassemble the scanner, please contact an authorized service provider.

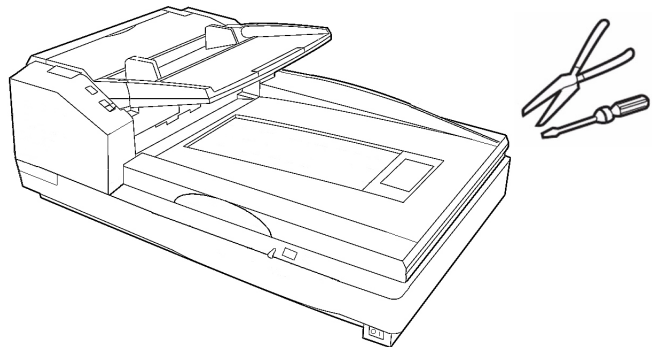

Do not place floppy disks or any items containing magnetic data strips on the flatbed. Magnets located in the flatbed sheet, which is attached to the flatbed cover, may damage data stored on floppy disks and magnetic strips.

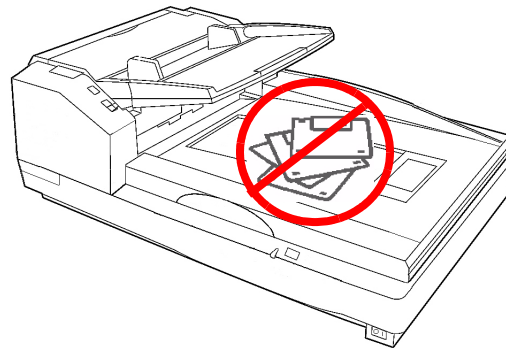



Caution



Do not place any liquids near the scanner. Accidental spillage of liquid into the scanner may cause severe damage. If this occurs, turn the scanner off and unplug the power cord. Please contact an authorized service provider.

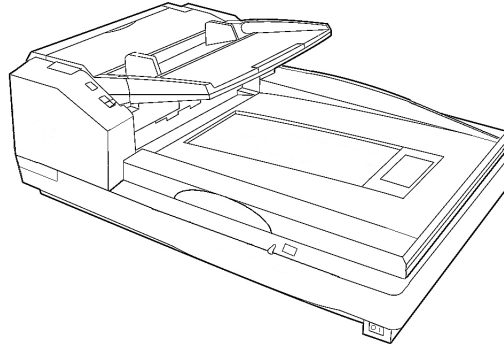

Liquids



Do not place books, paper, or other items on the scanner.

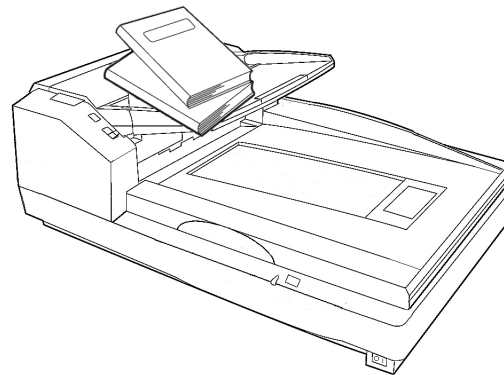

Do not place the scanner in an area where there is a lot of smoke, dust, chemical fumes or vibration.

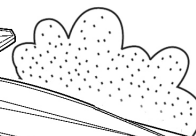
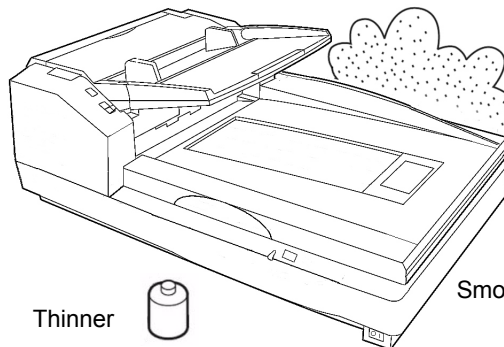

Dust

Thinner



Smoke





Caution



Do not leave the power cord plugged into the AC outlet if the scanner is not used for an extended period.

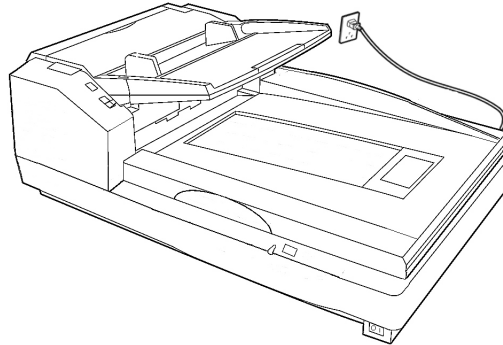

Do not place the scanner on an uneven or unstable surface.

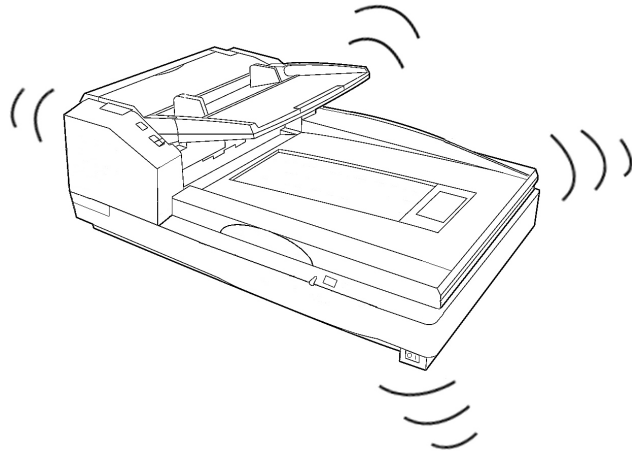

Do not use the feeder tray or the flatbed cover as a handle.

At least two people should carry the scanner. They should lift and hold the scanner securely with hands placed under the front and back sides.

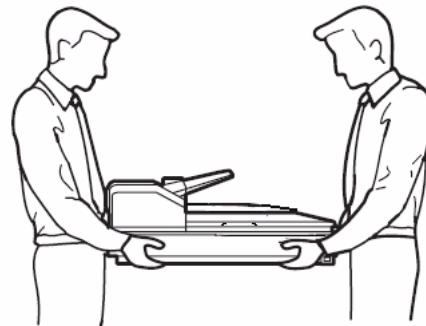



Caution



Do not look directly at the light of the scanner lamp. You may damage your eyes.

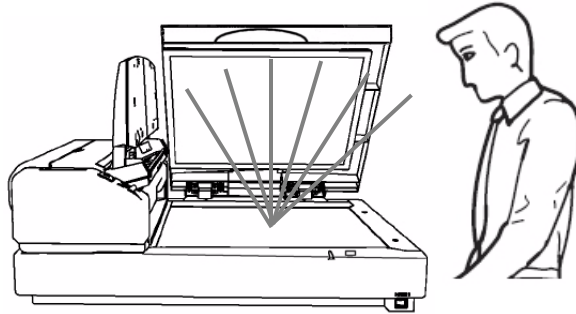

Do not place the scanner in direct sunlight or in a cold draft.

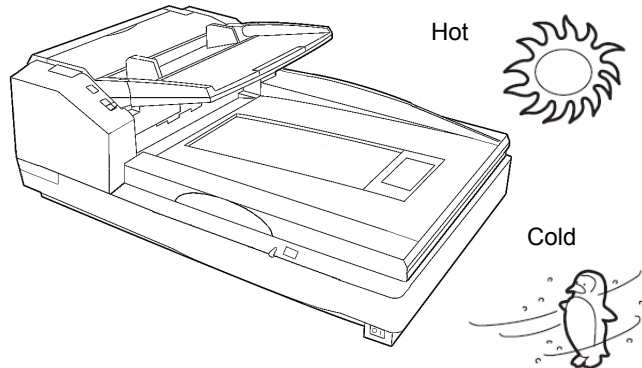

Do not place the scanner in a vertical position. The scanner cannot function in this position. Place the scanner only in a horizontal position.

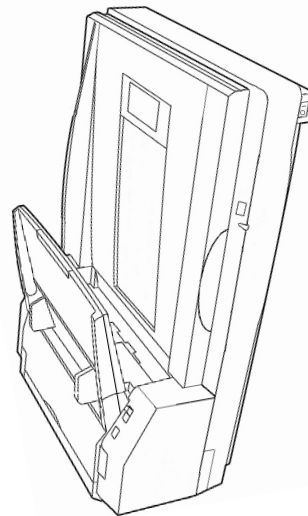



Caution



Do not place the scanner near a heating appliance or air conditioning vent. Do not place the scanner in a room with extremely high or low humidity.

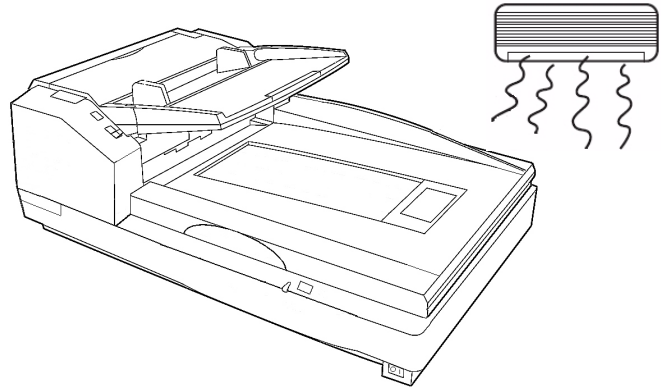

Do not place the scanner near other appliances or near machinery that generates large amounts of electromagnetic interference (EMI).

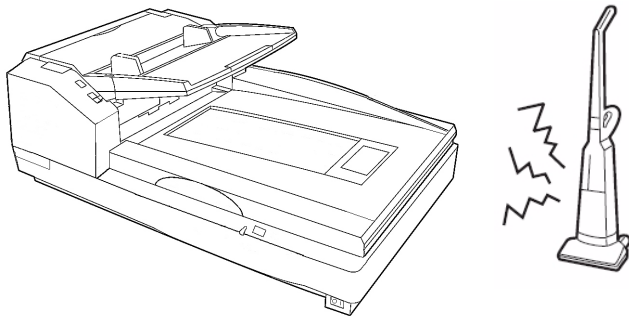

Do not place the scanner on carpet. Static electricity can cause the scanner to malfunction.

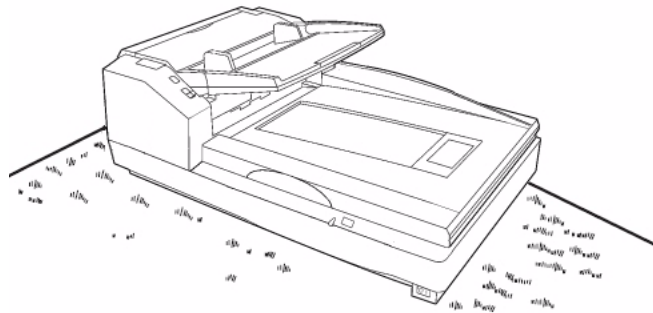

Power Source



Caution

- Power requirements: Power outlet with AC 100–120 V, 50/60 Hz or AC 220–240, V 50/60 Hz.
- Use a voltage level that does not vary more than $\pm 10\%$ from the voltage level marked on the scanner nameplate. The nameplate is located on the back side of the scanner.
- The scanner must be connected to a grounded outlet.
- The scanner should be used only with the power cord that is supplied with the scanner or with a power cord that has been approved by a certified electrical contractor.
- Do not use an extension cord.

Handling the CD-ROM

To prevent accidental damage to CD-ROMs, handle them carefully as shown below:

- Do not touch or write on the surface of the disc.

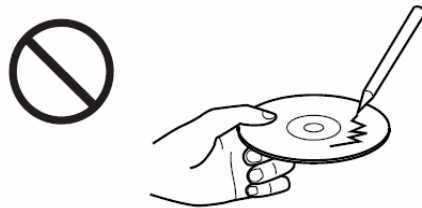

- Do not leave the disc out of the protective case.

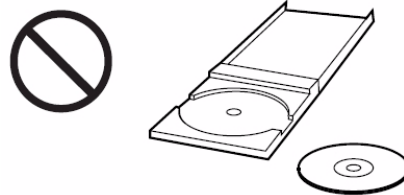

- Do not leave the disc in direct sunlight or near heat sources.

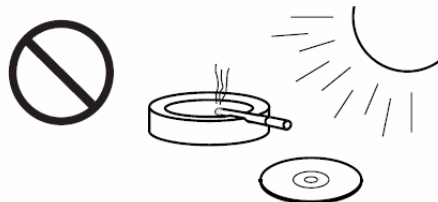

- Do not place heavy objects on the disc case or drop the case.

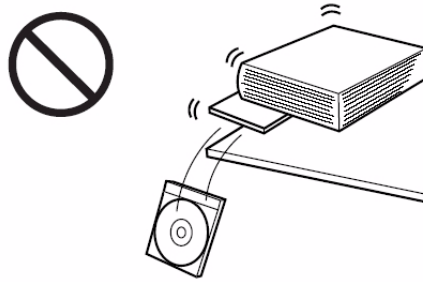

- To clean the disc, hold the disc by its edges and wipe it from the center to the edges with a dry, soft cloth.

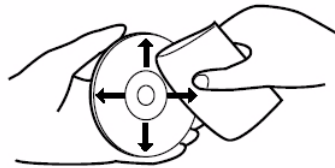

Installing the Scanner

Quick Installation Checklist

- 1** **Read the *Trüper Operator Manual* located on the Trüper Installation Resource CD-ROM.**

Insert the CD-ROM into the appropriate drive on the computer. Microsoft Autoplay will start, displaying the Select Your Language screen. Select your language and click **OK**. On the CD-ROM main menu select **View Manuals**, then select **View Trüper Manual**.

If Autoplay is disabled, go to the Windows taskbar, select **Start, Run** and type D:\SETUP.EXE, where “D” is the CD-ROM drive. Click **OK**. Select your language and click **OK**. Then locate the manual, as described above.
- 2** **Verify the computer system requirements.**

Refer to [“Computer System Requirements” on page 13](#).
- 3** **Attach the feeder tray to the scanner.**
- 4** **Connect the scanner.**

Refer to [“Initial Setup and Installation” on page 28](#).
- 5** **Install the software.**

Refer to [“Initial Setup and Installation” on page 28](#). You can also access the *Trüper Operator Manual* from the Trüper User Utility. Click the **Trüper User Utility** icon on your Windows desktop, then click **Help**.
- 6** **You are now ready to scan.**

Refer to the instructions for your scanning or document management software application.

Unpacking the Scanner

Unpack the scanner unit and the included parts. Be sure that all parts are present before installing the scanner. If there are any missing parts, please contact the reseller where you purchased the Trüper scanner.

Note

It is highly recommended that you keep the original carton and all the packing materials in case you need them later. See the [“Repacking Instructions” on page 117](#).

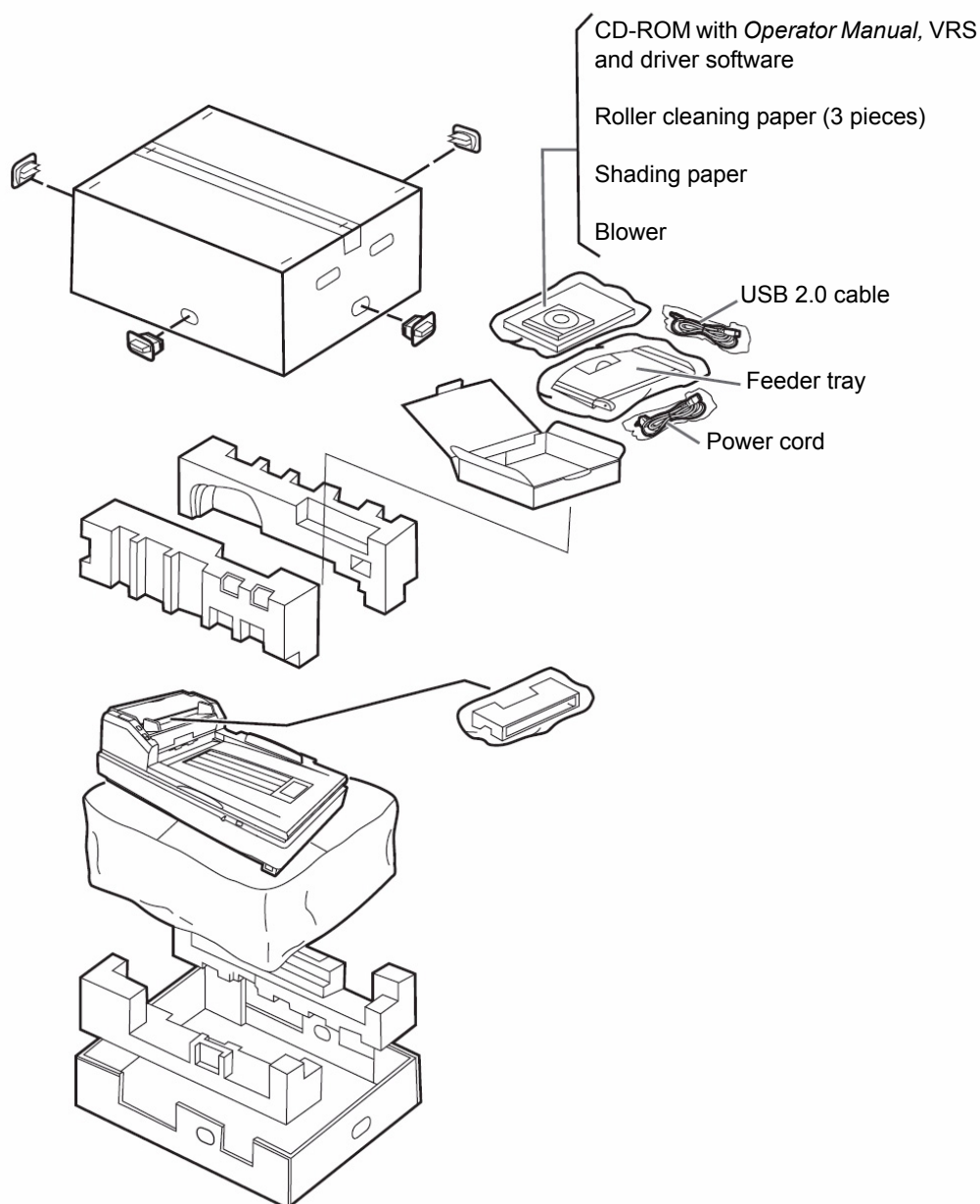

Attaching the Feeder Tray

- 1** Install the left side of the feeder tray by inserting the pin located in the left side of the feeder into the hole located on the left arm of the feeder tray.

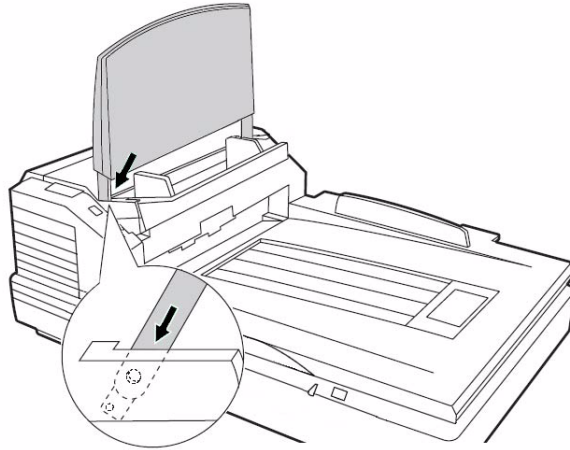

- 2** Install the right side of the feeder tray by inserting the pin located in the right side of the feeder into the hole located on the right arm of the feeder tray. A small amount of pressure will be required to align the pin with the hole.

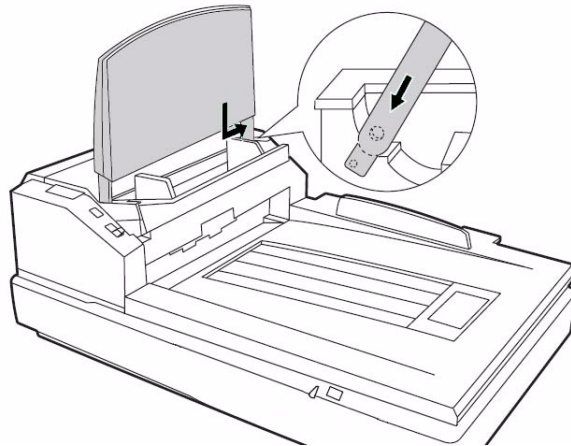

Initial Setup and Installation

Connecting the Scanner

- 1** Turn off the power for the computer.
- 2** Plug the scanner power cord into the AC power input on the back of the scanner and connect the other end to a power outlet.
- 3** Connect the supplied USB cable to an available USB 2.0 port on the computer and connect the other end to the USB connector on the scanner.
 - Use the supplied USB cable.
 - Do not connect the scanner to a USB hub. A hub connection is not guaranteed to work.

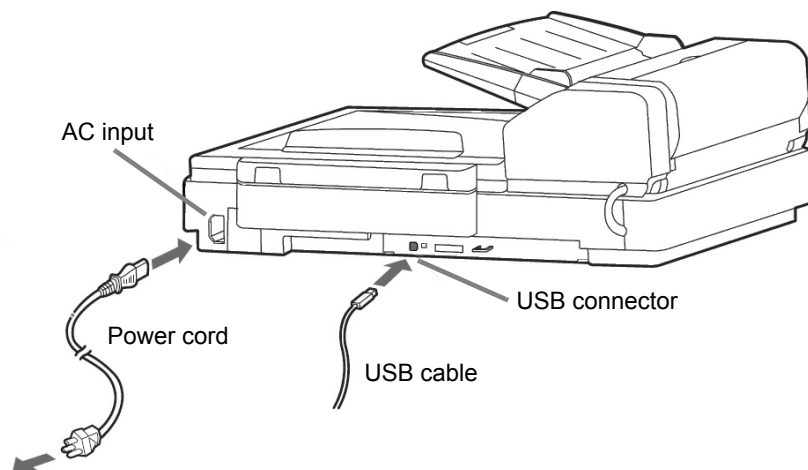

Note

Do not connect a USB and a SCSI cable to the scanner at the same time.

Installing the Windows Scanner Driver

- 1** Press the scanner power switch to the ON position.
 - The LED will at first display a flashing orange light.
 - The scanner is ready when the LED displays a steady green light.

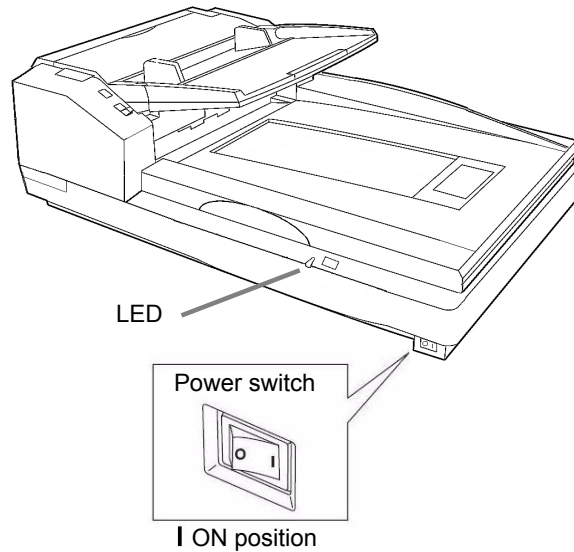

- 2** Turn on the power for the computer.

3 In Windows 2000 or Windows XP, log on with Administrator privileges. Windows will detect the scanner and start the Found New Hardware Wizard. Follow the procedure described in the following steps and diagrams:

1. Click **Next**.



2. Select **Search for a suitable driver for my device**, then click **Next**.

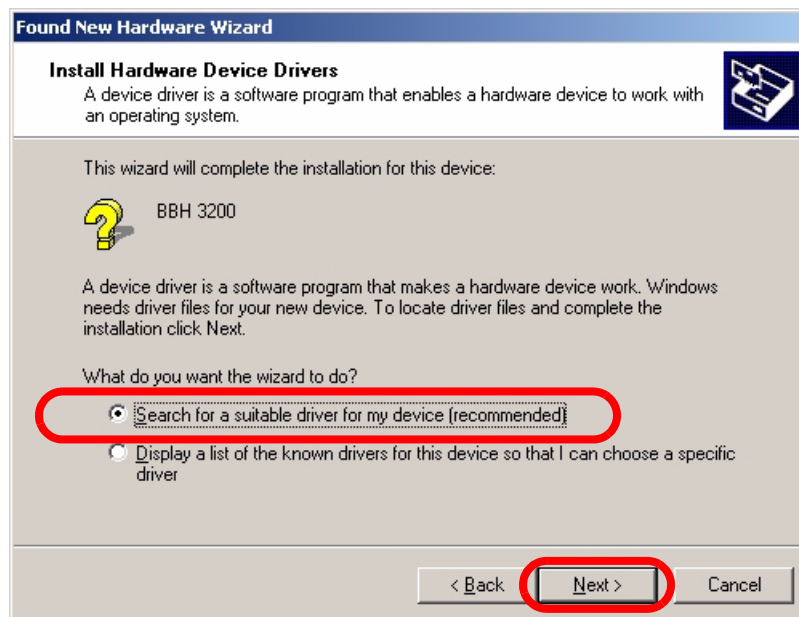

3. Select **CD-ROM drives**, then click **Next**.

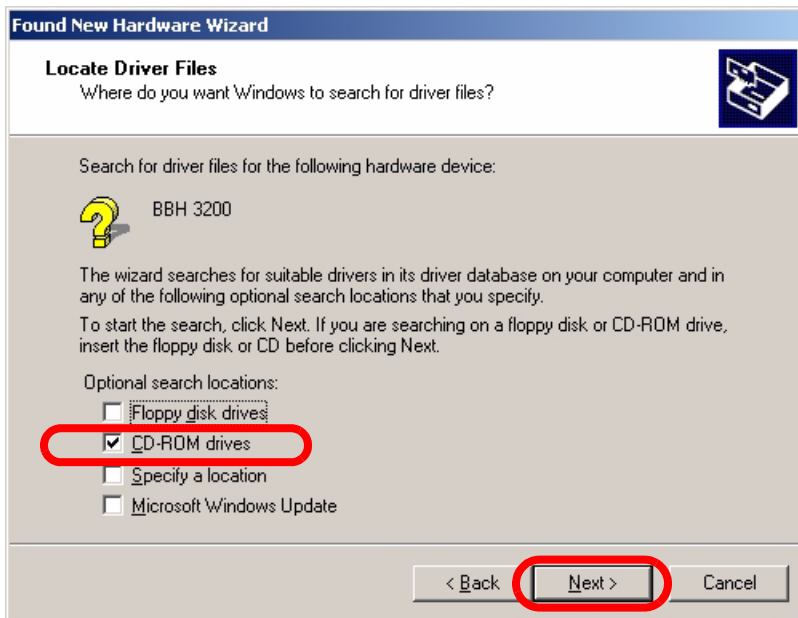

4. Insert the Trüper Installation Resource CD-ROM into the appropriate drive on the computer.

5. When Windows finds the device driver, click **Next**.

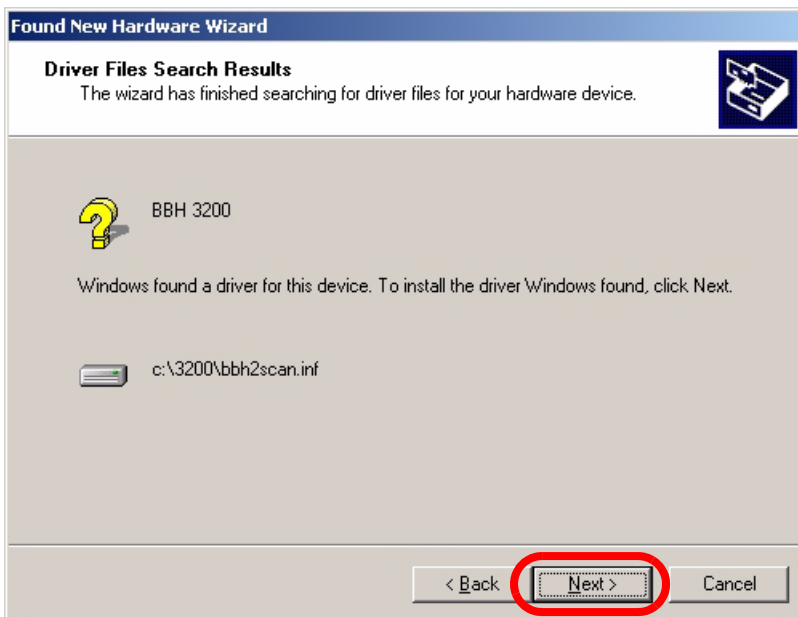

6. If Windows cannot find the driver files, use the **Browse** option in the Files Needed dialog box. Browse to the folder D:\minidriver, where “D” is the letter for the drive that contains the Trüper CD-ROM. If there is no request for files needed, continue with the next step.

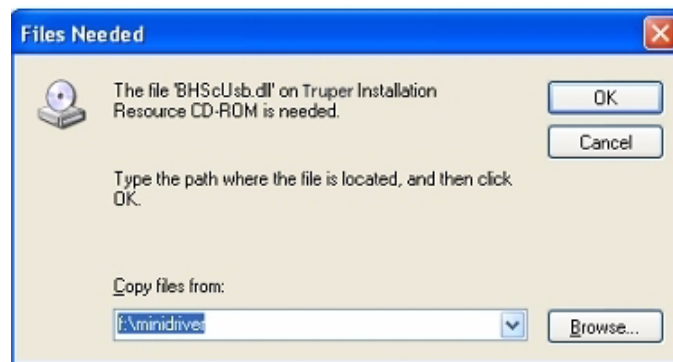

7. If the Windows XP compatibility message appears, click **Continue Anyway**.

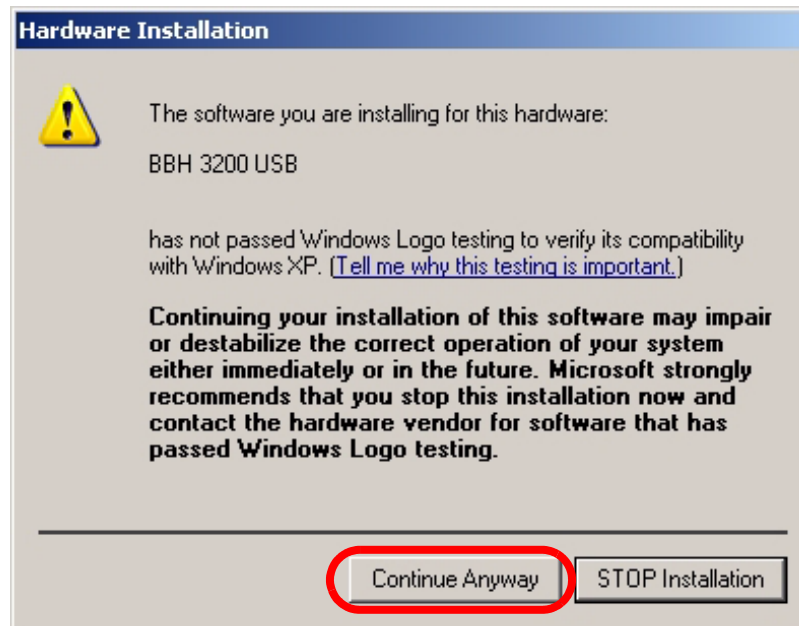

8. The Found New Hardware Wizard will now complete the installation of the driver. When the wizard has finished, click **Finish** to complete the installation.



9. Restart the computer.

Trüper Software Installation

Installing the Software

- 1 Insert the Trüper Installation Resource CD-ROM in the CD-ROM drive of the computer.
 - If Microsoft Autoplay is active, the installation menu will appear and you can continue with the next step.
 - If the installation menu does not appear, select the Windows option **Start, Run** and type D:\ where "D" is the letter of drive that contains the Trüper CD-ROM. Locate the file **setup.exe** on the CD-ROM and double click the file to open the installation menu.

- 2 Select your language from the language dialog box, then click **OK**.



- 3 Click **Install Software** from the Main Menu.

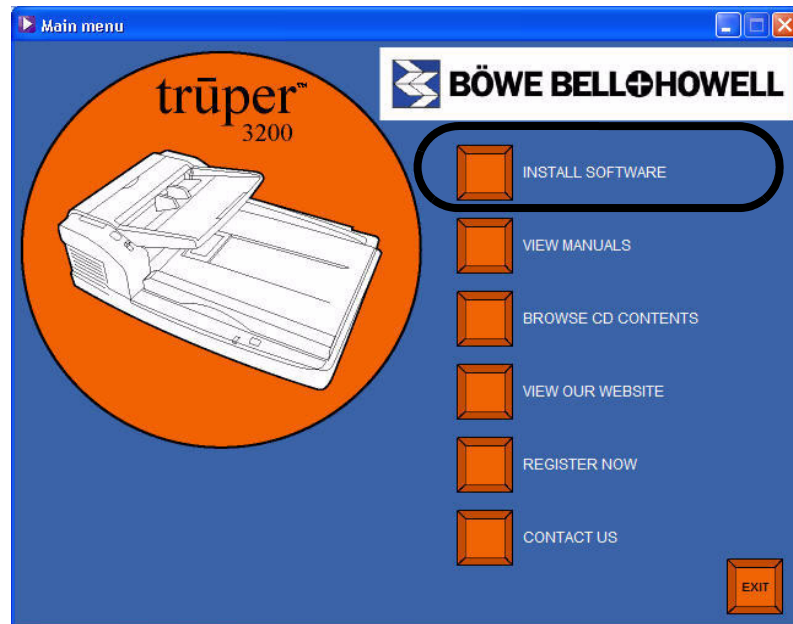

Click the Install Software steps sequentially, Step 1 to Step 4. In Windows 2000 or Windows XP, you will need to log on to the computer with Administrator privileges in order to complete the installation. Please refer to your Windows user manual or call your information technology department to find out how to log on with Administrator privileges.

4 User Utility

1. Click **Step 1 User Utility**. The User Utility must be installed to properly operate the scanner.

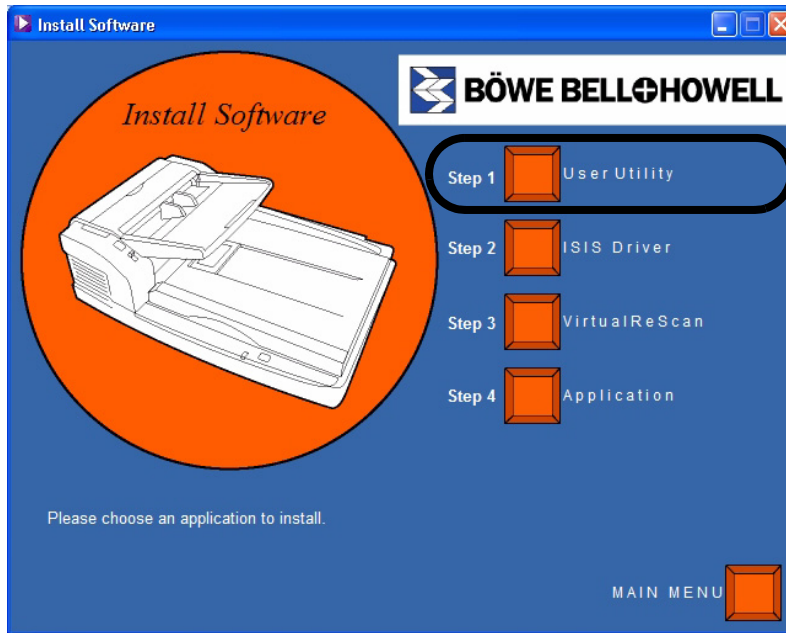

2. Read the license agreement and click **Yes** to accept the agreement.

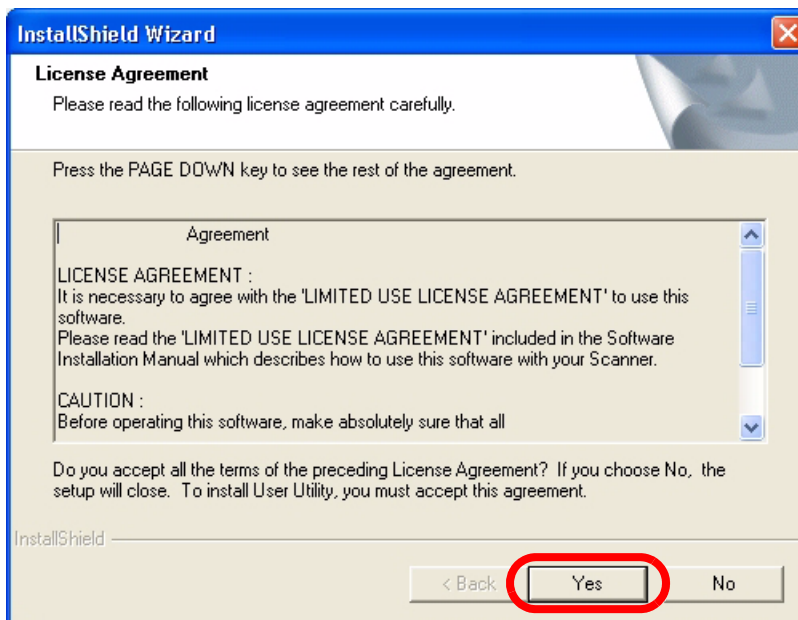

3. Click **Next** to select the default destination folder for the program files (recommended). To install the files in a different folder, click **Browse** and select a different destination, then click **OK** in the Choose Folder window.

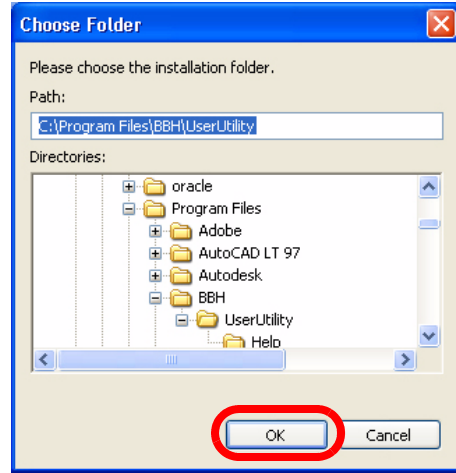
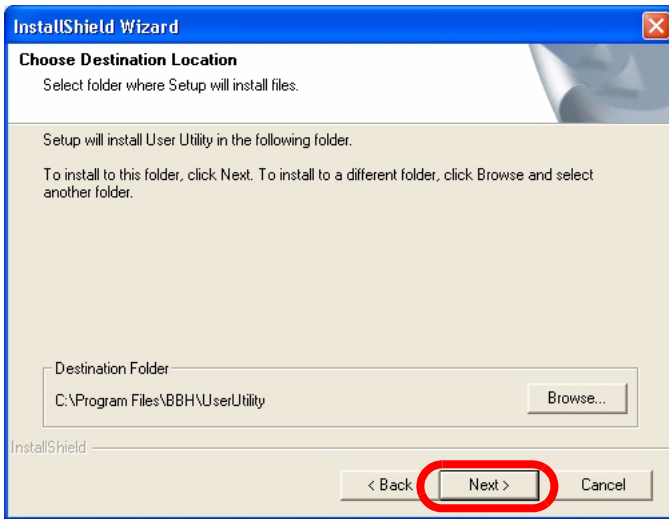

4. Click **Next** to select the default folder for program icons.

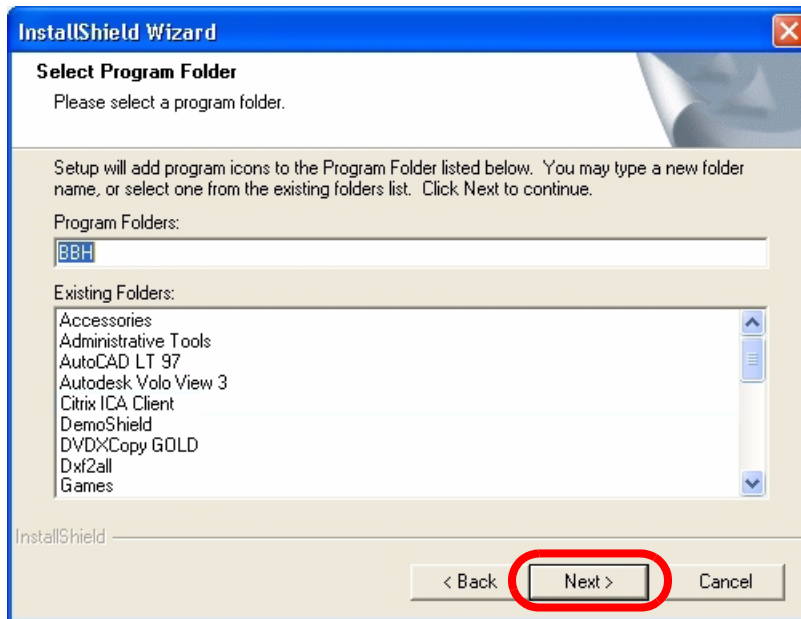

The User Utility Setup is performing the installation.

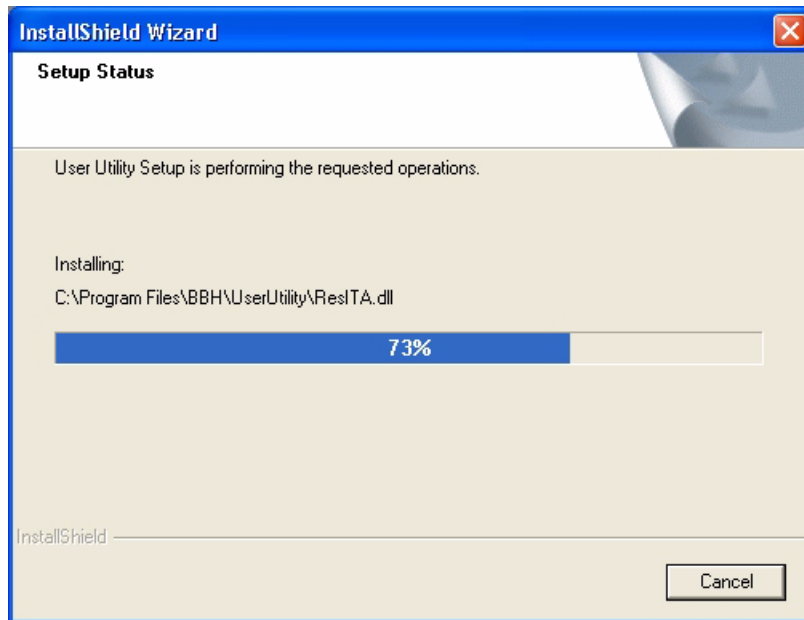

5. When the setup is complete, click **Finish**.

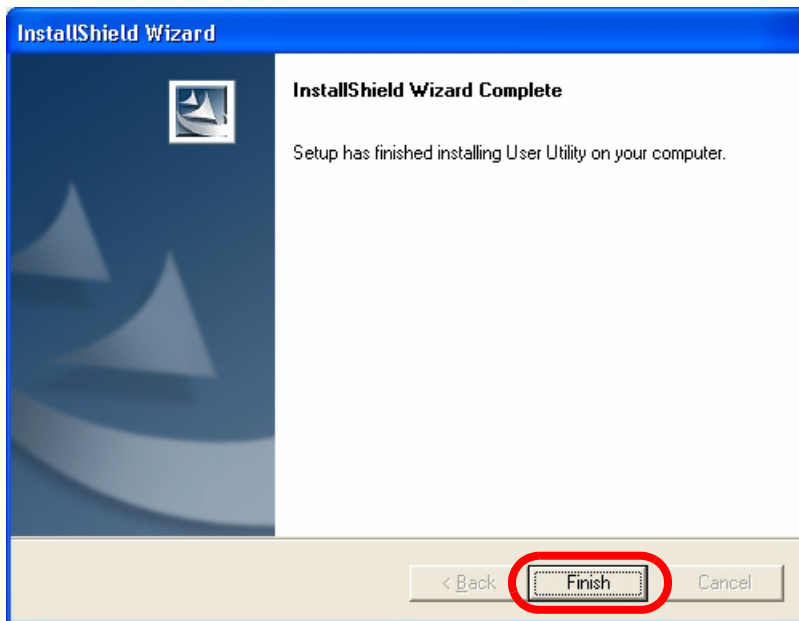

The Trüper User Utility Help files will automatically install.

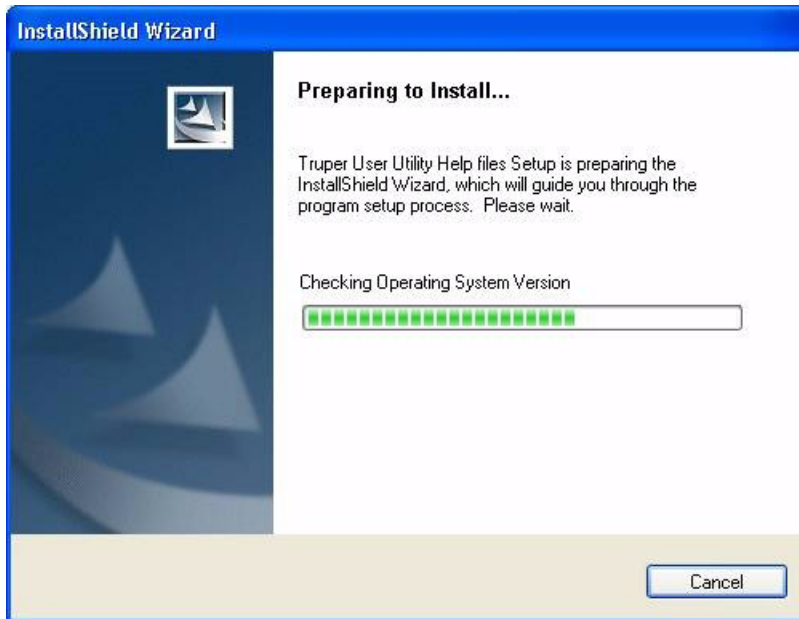

6. Click **Next** to continue.



7. When the setup is complete, click **Finish**.

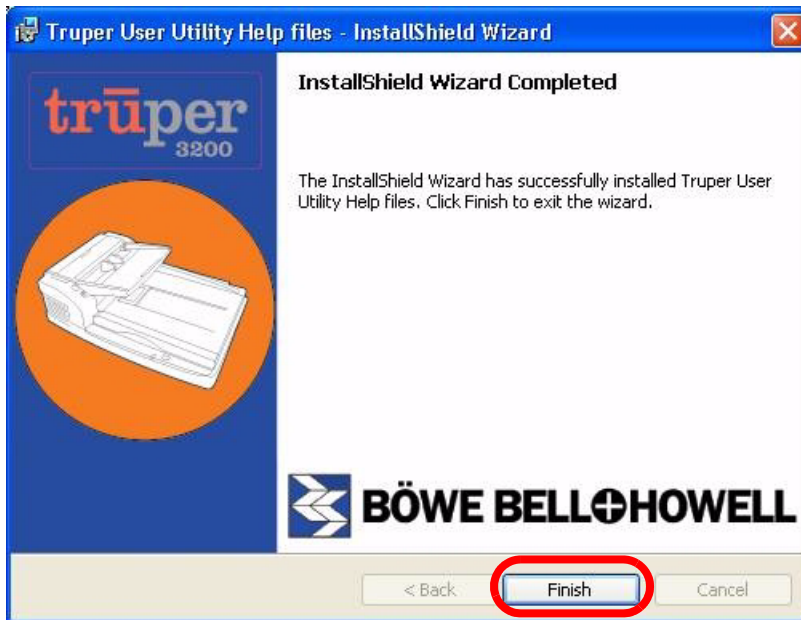

5 ISIS Driver

1. Click **Step 2 ISIS Driver**. The Pixel Translations BBH 3200 ISIS driver must be installed to properly operate the scanner.

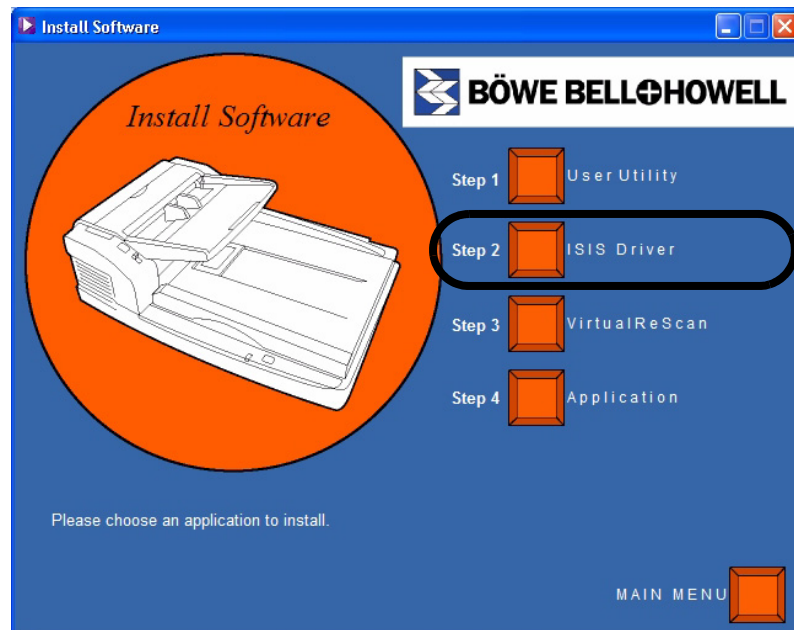

2. Read the license agreement and click **Yes** to accept the agreement.

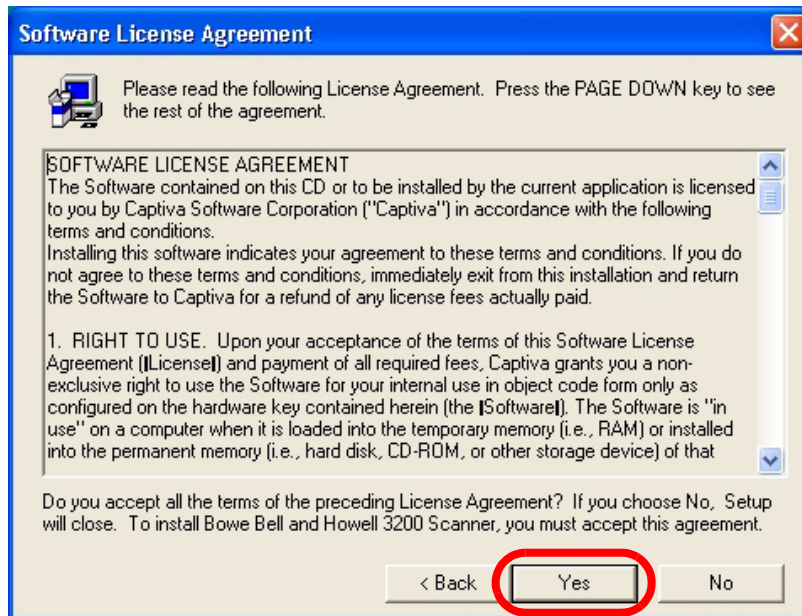

3. Close all other Windows programs, then click **Next**.

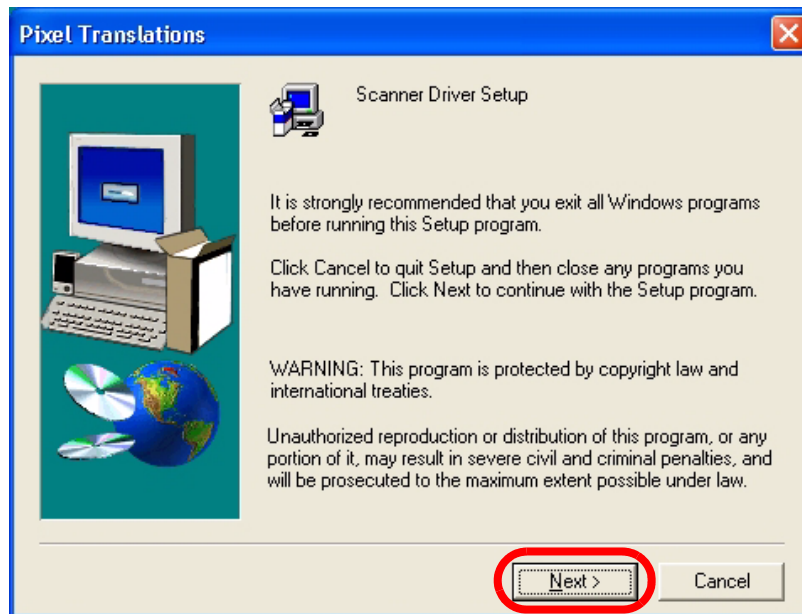

The ISIS Driver Setup is performing the installation.

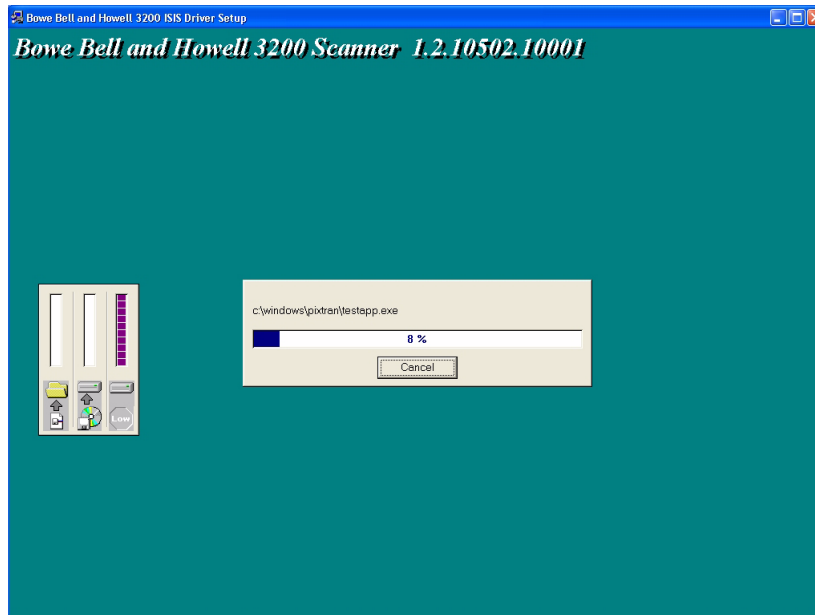

4. When the setup is complete, select **No, I will restart my computer later**, then click **Finish**.

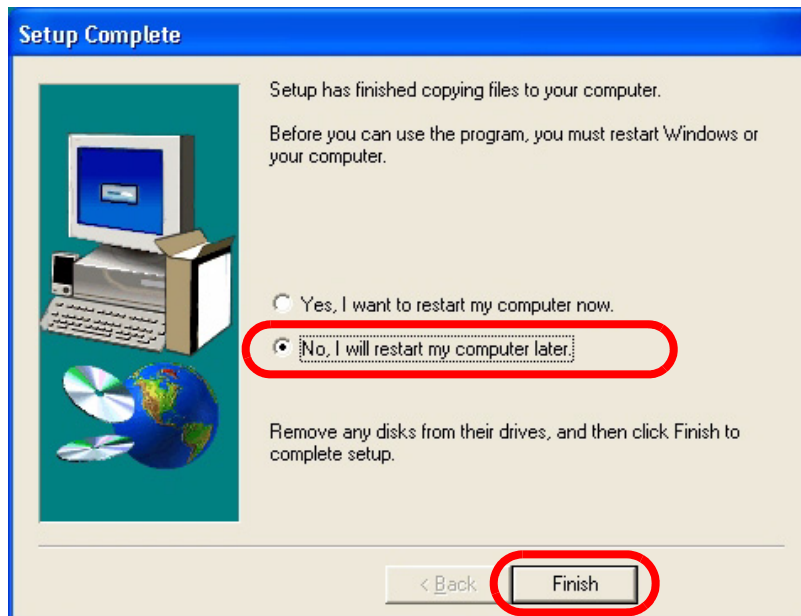

Note

If you select the option to restart the computer, you will also need to restart the scanner. After you restart the computer, log on with Administrator privileges, then select **Start** and **Run** on the taskbar. In the Run dialog box type `D:\setup.exe`, where "D" is the letter for the drive that contains the Trüper CD-ROM. Then click **OK** to start the setup. Select your language, then select **Install Software** from the installation Main Menu.

6 VirtualReScan

1. Click **Step 3 VirtualReScan**.

More detailed information about VRS installation is available in the *VirtualReScan Installation Guide* on the Trüper Installation Resource CD-ROM. Select **View Manuals** on the installation Main Menu.

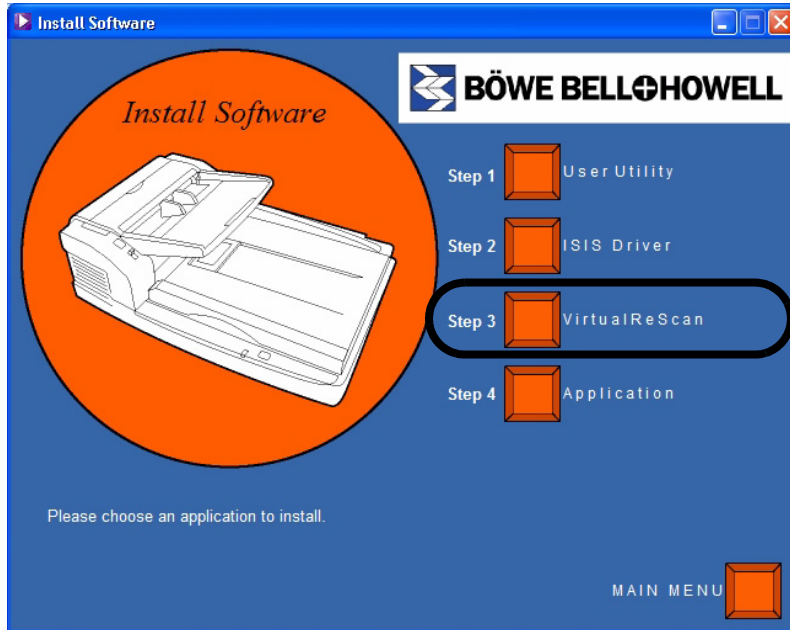

2. The installation wizard is preparing to install VRS.

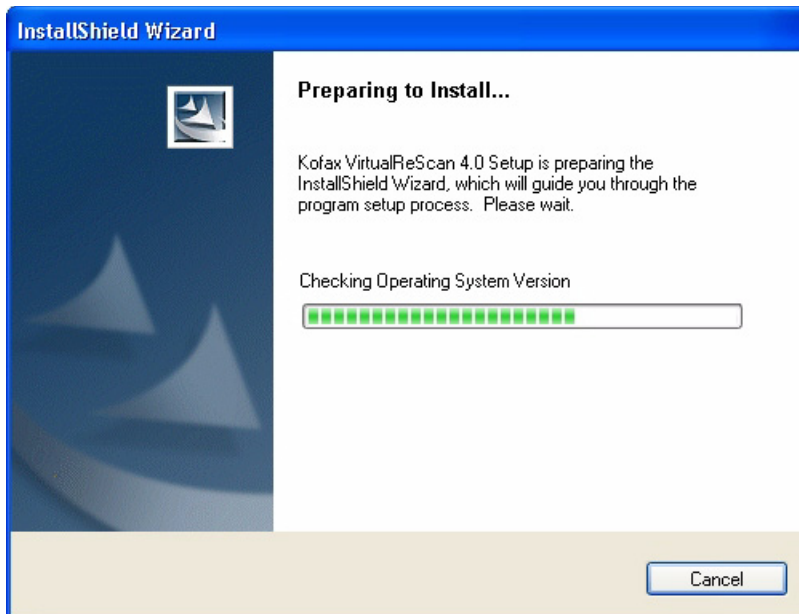

3. The **Install VRS only** option is selected by default. Click **Next** to continue.

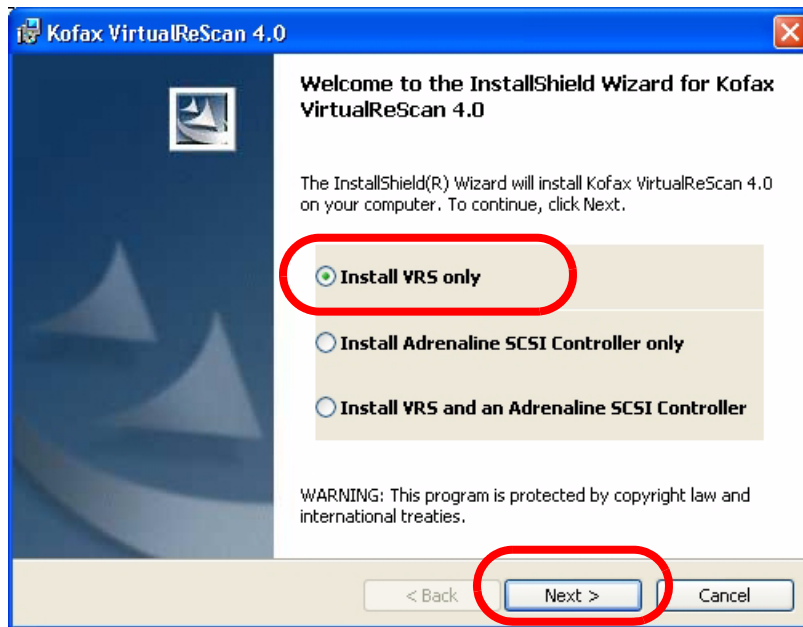

4. Enter your name, company name and e-mail address for VRS product registration. If you do not wish to be contacted with VRS product-related information, select the contact option check box. Click **Next** to continue.

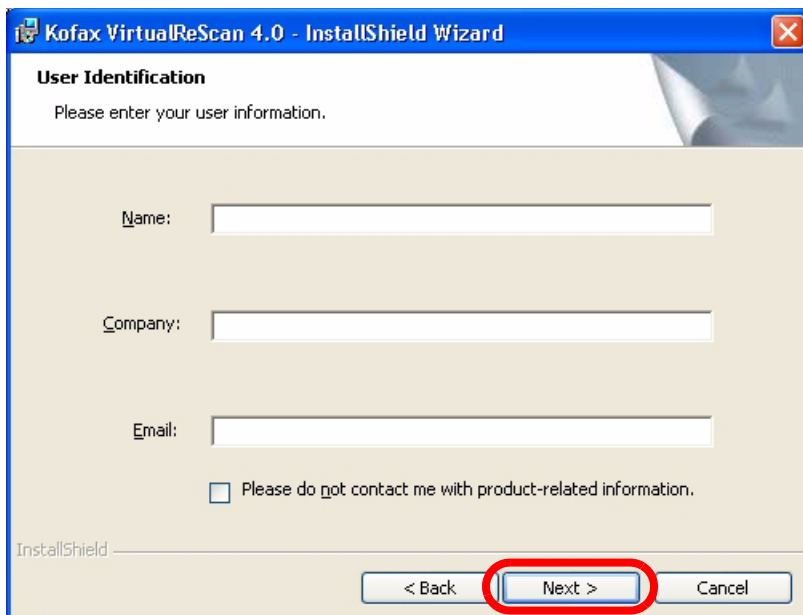

5. The Part Number, Serial Number and Product Code for VRS software is automatically populated. Click **Next** to continue.

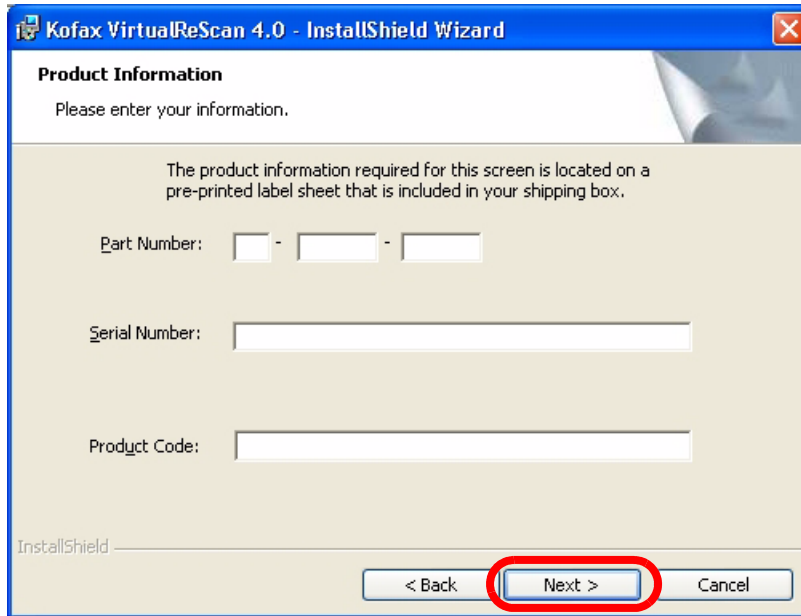

6. Click **Next** to select the default destination folder for the program files (recommended). To install the files in a different folder, click **Change** and select a different destination, then click **OK**.

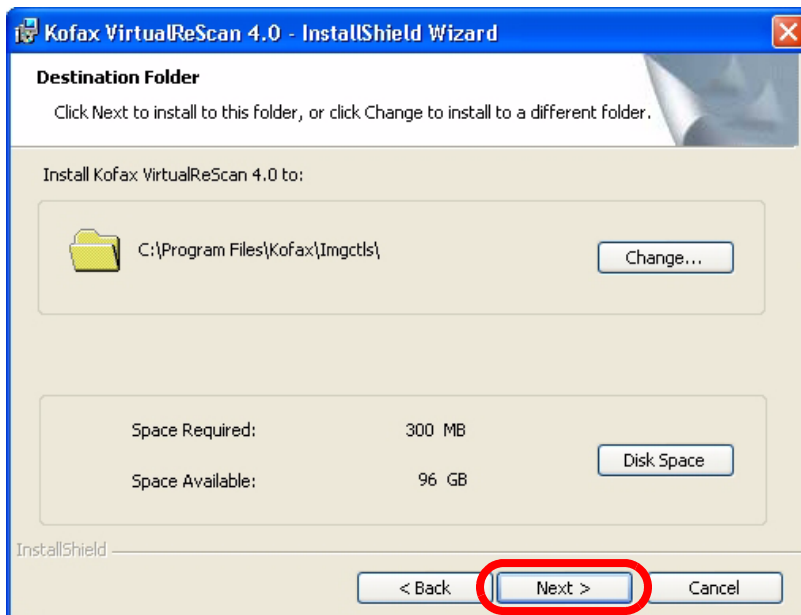

7. Select **BBH 3200 USB**, then click **Next** to configure the scanner.

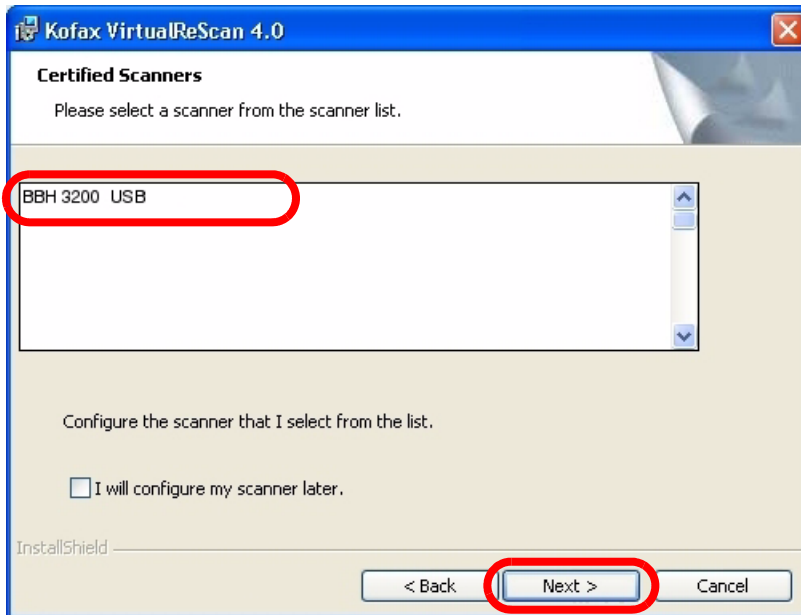

8. Click **Install**.

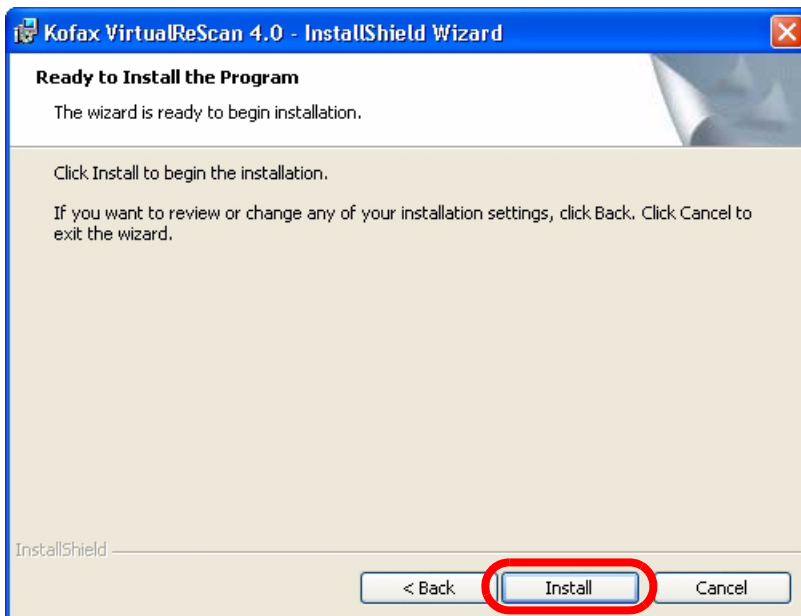

The installation wizard will perform the installation.

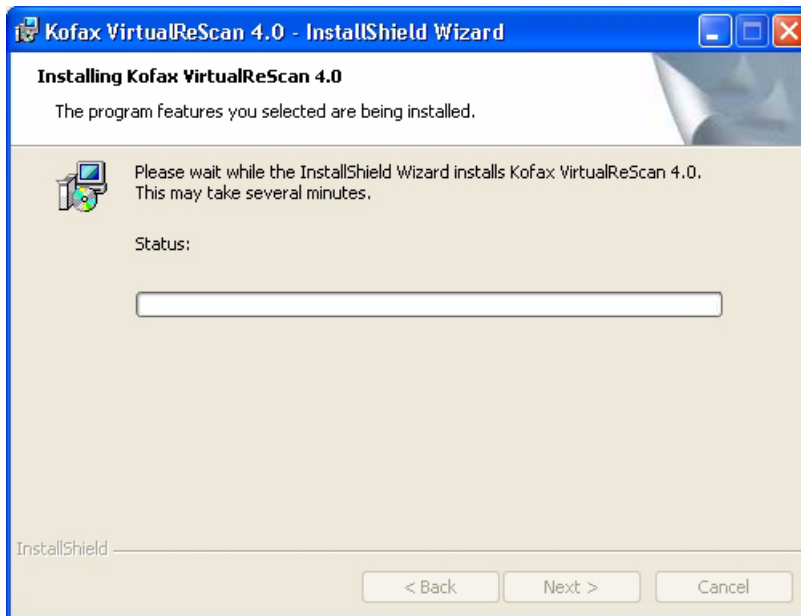

9. Please ignore by clicking **OK** in the Sentinel dialog box. (Sentinel is a licensing utility for VRS.)

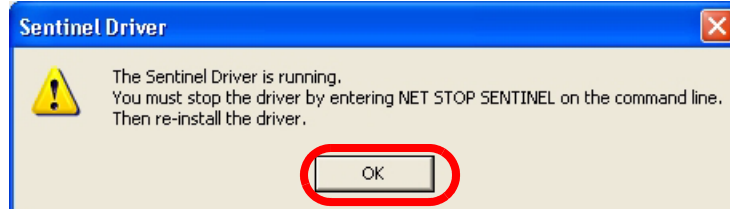

10. When the installation is complete, click **Finish**.

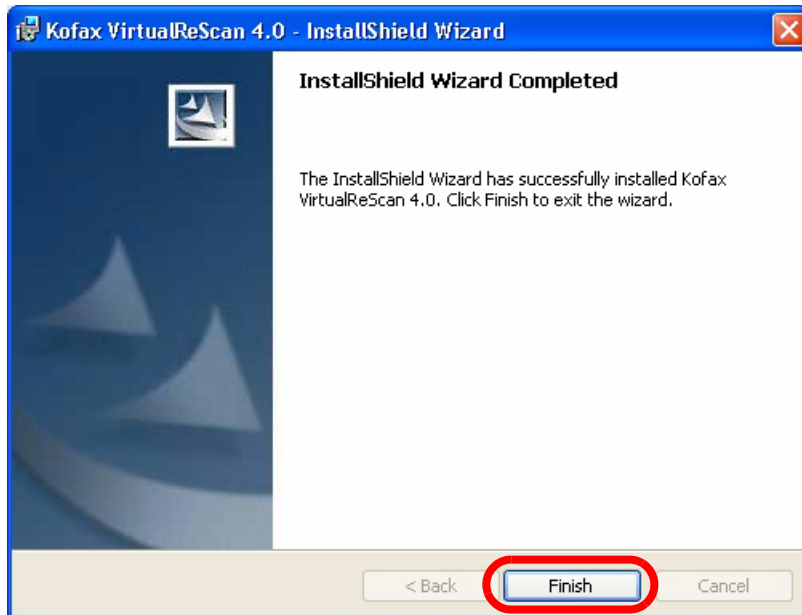

11. Click **Yes** to restart the computer.

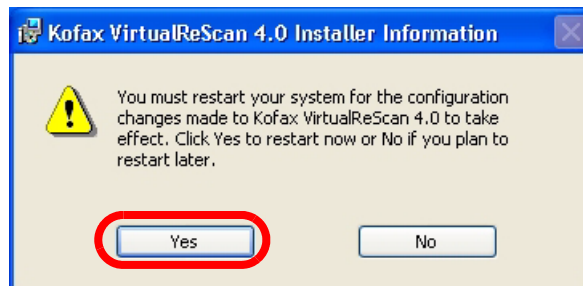

7 Step 4 Application

1. Click **Step 4 Application** to install your scanning application.

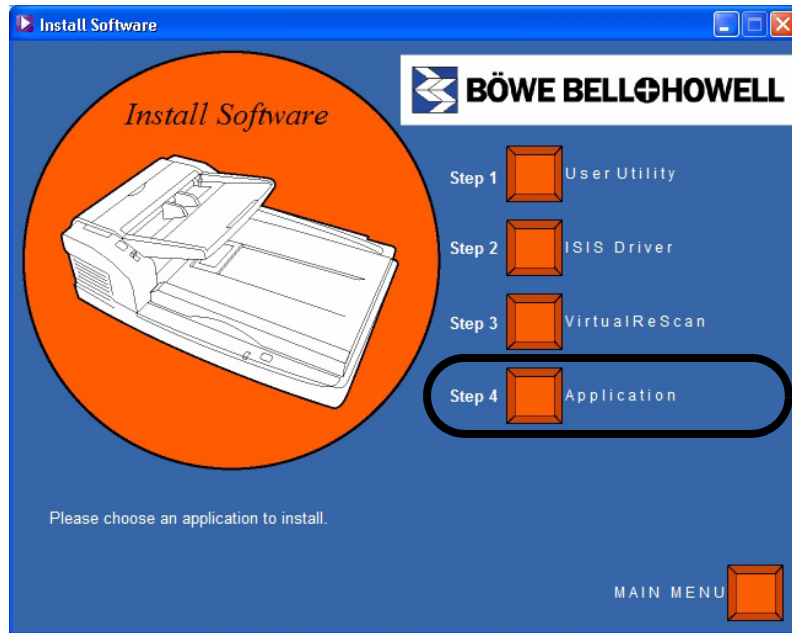

Driver Selection: Scanning Applications with VRS Connectivity

VirtualReScan is compatible with most scanning applications. When starting your scanning application, you may be requested to select a scanner or a scanner source. Depending on your application, select one of the following:

- For ImageControls applications, set Scanner Source to: Bowe Bell & Howell 3200 with SVRS.
- For ISIS applications, set Scanner Selection to: Kofax VRS Scanner. This is the certified ISIS driver for this configuration. **DO NOT select Bowe Bell and Howell 3200.**
- For TWAIN applications, set Scanner Selection to: Kofax Software VRS - TWAIN.

Contact your application reseller for more information.

Scanning Applications with Direct ISIS connectivity

Occasionally, an ISIS application based on PixTools may not support the recommended VRS-based ISIS driver. Check with your application reseller to determine if your scanning application is compatible with VRS or requires the use of a Direct ISIS driver. For Direct ISIS connectivity, select the following driver:

- ISIS Application Scanner Selection: Bowe Bell and Howell 3200. This is the certified ISIS driver for direct connectivity.

View Manuals

The *Trüper Operator Manual* and VRS manuals are available on the Trüper Installation Resource CD-ROM. To view the manuals you will need Adobe Acrobat Reader.

- 1** Insert the CD-ROM in the computer.
- 2** Click **View Manuals** from the Main Menu.
- 3** Select a manual from the list.

Contents of the Installation Resource CD-ROM

- Install Software
 1. User Utility
 2. ISIS Driver
 3. VRS
 4. Application (scanning application)
- View Manuals
 - Trüper Operator Manual*
 - VRS Manuals
- Browse CD Contents
- View Our Website
- Register Now
- Contact Us

Operating the Scanner

Turning on the Scanner

- 1** Turn on the scanner.
 - Press the power switch to the ON position.
 - The LED will at first display a flashing orange light.
 - The scanner is ready for scanning when the LED displays a steady green light.

- 2** After the scanner's LED light is green, turn on the computer.

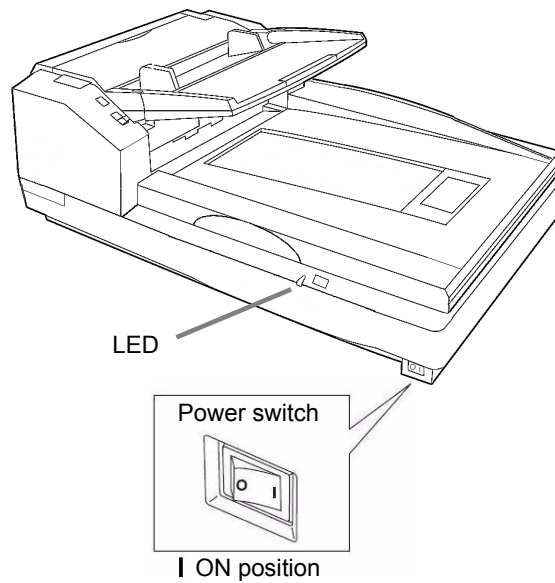

LED Status Indicator

The color of the LED light indicates the status of the scanner:

LED Light	Status
Green	Ready to scan or scanning in process
Green (flashing)	Sleep mode
Orange	Ready to scan or scanning with warning ¹
Orange (flashing)	Initializing -- or -- Sleeping with warning ²
Red	An error occurred ²

1. The rollers need to be cleaned or replaced.
2. Check the status of the scanner using the Trüper User Utility included on the CD-ROM or by clicking the  icon on the computer desktop.

Document Preparation

Prepare the documents you want to scan according to the guidelines and recommendations in this section.

General Guidelines

Do not scan official documents or copyrighted material:

- Do NOT scan currency.
- Do NOT scan copyrighted material or the work of others except for private use or when authorized by the copyright owner or owners.
- Do NOT scan certificates, licenses, passports, or official or private documents except when such work is authorized.

Guidelines for Using the ADF

For best results, follow these guidelines for documents that will be scanned using the ADF (Automatic Document Feeder):



Caution

Prior to scanning with the ADF, remove all staples and paper clips from sheets.

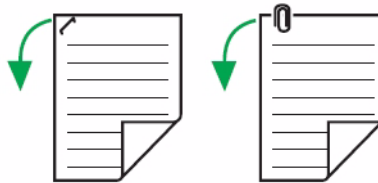

Recommended paper: Plain paper with a maximum sheet thickness of 2.0 to 5.9 mils (0.05 to 0.15 mm) and weight of 10.6 to 34 pounds (40 to 127 grams/meter²). 1 mil = 1/1000 inch. The weight in pounds of paper represents the weight of 500 sheets in the “basic sheet size” of the paper, in this case 17 x 22 inches (432 x 559 mm). The basic sheet size is not the same for all types of paper.

Acceptable document size for the ADF:

1.90 - 11.70 inches (40 - 297 mm)

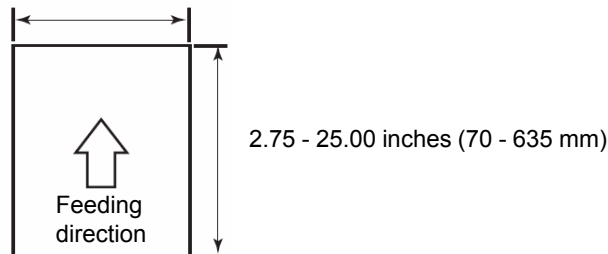

Glued or curled documents may cause a paper jam or damage the ADF unit. Scan this type of document using the flatbed.

The height of the documents placed in the feeder tray must not exceed the paper limit mark that appears on the right side of the document guide. ([See the diagram on page 58.](#))

The following chart indicates the maximum number of sheets that can be loaded on the feeder tray:

Paper weight (pounds)	11	14	17	20	21	24	28	34
Paper weight (grams/meter²)	40	52	64	75	80	90	104	127
Maximum number of sheets	320	260	200	170	160	140	120	100

Sheets that are exceptionally thick or thin should be placed in the ADF manually, one sheet at a time, or they should be scanned using the flatbed.

Curled, wrinkled, or folded documents may not scan properly. Check the allowances for curl and fold in the following diagram:

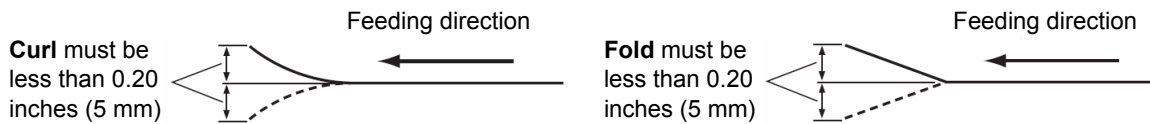

Types of Documents to Avoid in the ADF

The following types of documents may cause jams in the ADF or may cause the ADF to feed more than one sheet at a time. It is recommended that you use the flatbed to scan these types of documents:

- Overhead projector sheets, other plastic films, cloths or metallic sheets
- Paper with irregularities such as tabs, staples, paste and similar items
- Documents with wet ink
- Thick or irregular documents such as envelopes or documents that are glued together
- Thermal or heat sensitive paper
- Tracing paper
- Copying paper such as carbon paper
- Damaged or wrinkled documents
- Photographs
- Coated paper
- Thick plastic cards such as credit cards or identification cards
- Torn sheets and documents with notches or holes, or punched or perforated sheets
- Extremely smooth or shiny paper
- Paper that is highly textured
- Paper with carbon sheets
- Carbonless (NCR) paper

If a jam occurs in the document feeder, reduce the number of sheets loaded on the feeder to about 20.

If a paper jam or feeding of more than one sheet occurs, clean the rollers as described beginning on [page 81](#).

If the document is not properly scanned, try one or more of the following procedures:

- Scan the documents by feeding individual sheets [manually into the ADF](#).
- [Scan the documents with the flatbed](#).

Using the Trüper ADF

The Trüper ADF (Automatic Document Feeder) enables multiple sheet scanning. For the best results when scanning multiple sheets, follow the document preparation recommendations and procedures as described in [“Document Preparation” on page 52](#). To load documents in the ADF, perform the following procedure:



Caution

Prior to scanning with the ADF, remove all staples and paper clips from sheets.

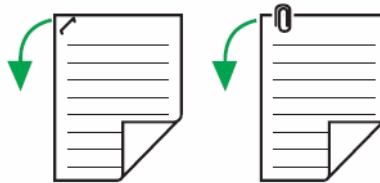

- 1** Separate documents that have been stapled or clipped together. Remove glued documents and documents that are curled; these types of document may cause a paper jam and damage the unit. These types of documents should be scanned using the flatbed.

1. Fan the stack of documents to separate all the sheets. Be sure the edges of the sheets do not stick together.
2. Hold both edges of the sheets and bend the documents.
3. To flatten the documents, hold firmly then pull them apart.

Repeat these steps as necessary to be sure the stack of documents is completely separated.

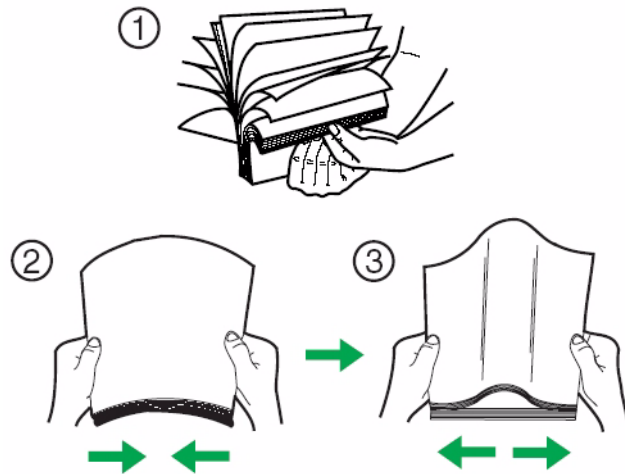

- 2** Carefully align the documents.

- 3** Adjust the document guides on the ADF so that they are slightly wider than the size of the document.

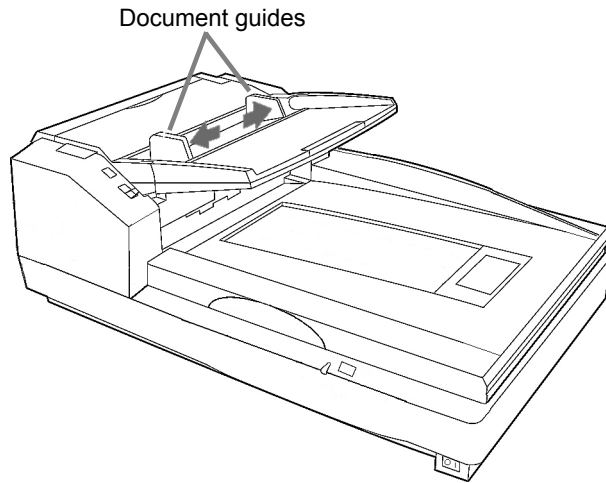

- 4** Set the feed selector switch to AUTO.

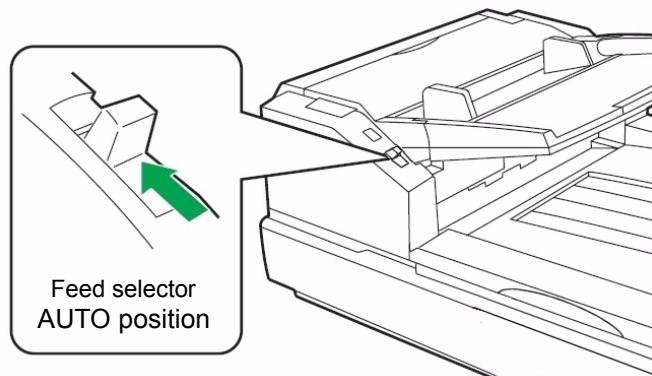

5 When scanning documents that are longer than the feeder tray, you can pull out the feeder extension tray, which is located near the edge of the feeder tray. The extension tray will support documents up to 15 inches (381 mm) long.

To handle longer paper in the exit tray, extend the exit stopper. Adjust the position of the exit stopper so that it will accommodate the length of the documents. The exit stopper is adjustable to 17 inches (432 mm). When scanning a document longer than 17 inches (432 mm) or A3 size (420 mm), fold down the exit stopper so that the longer paper will fit in the exit tray.

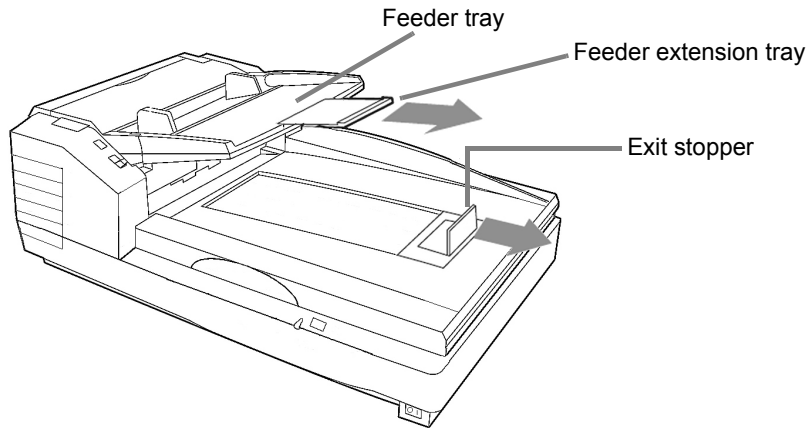

6 Load the documents on the feeder tray with the side to be scanned facing up. Note the directional "Face Up" icon and the document sizing scale on the ADF door. Slowly push the sheets in the direction of the arrow until they stop.

To scan in portrait mode, load the documents with the top edge going first into the feeder. To scan in landscape mode, load the documents with the left edge going first into the feeder, as shown in the following diagrams.



Caution

The height of the documents placed in the feeder tray must not exceed the paper limit mark that appears on the right side of the document guide. Placing more sheets in the feeder tray may cause a paper jam.

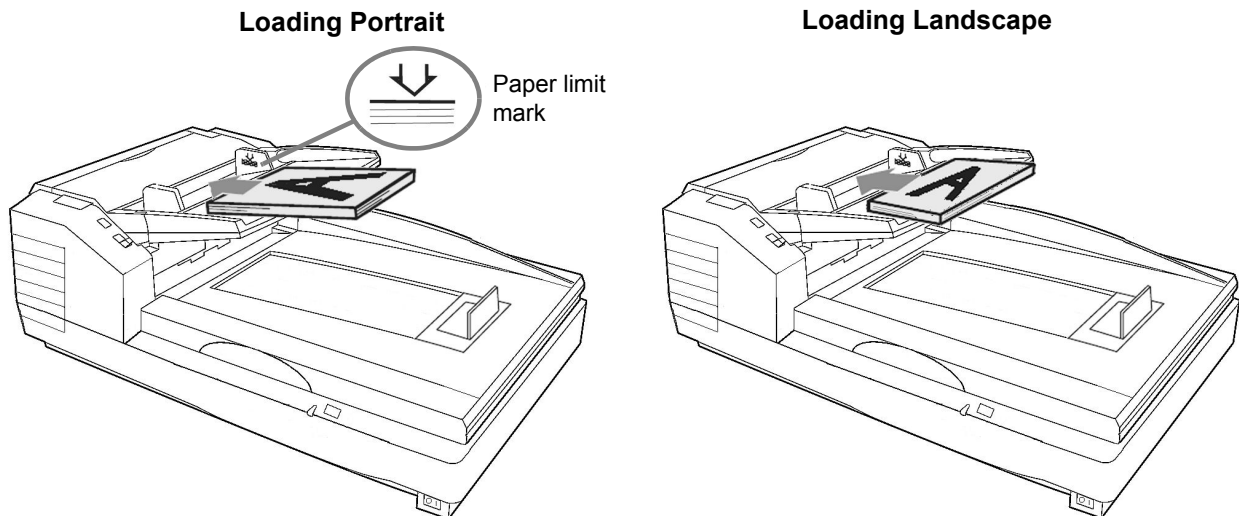

7

Do the following to configure the driver:

- Open the Scanner Properties window.
- Select **ADF** from the **Source** drop-down list and click **OK**.

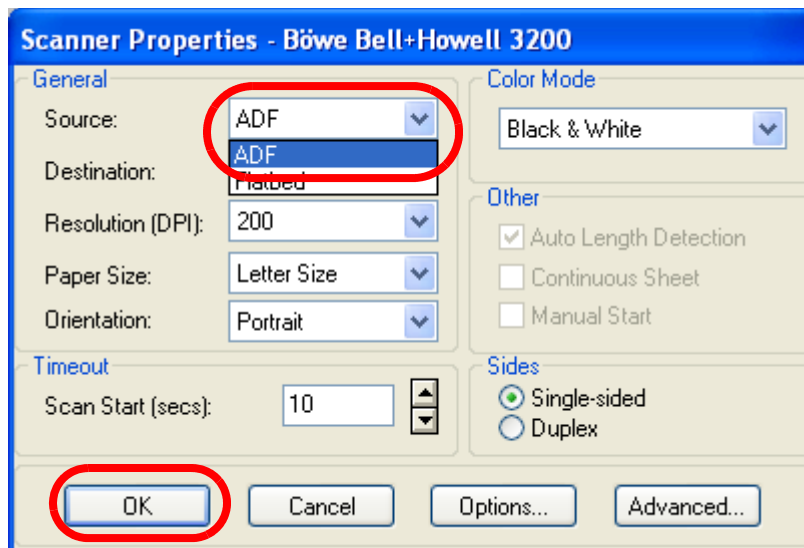

You are now ready to scan. Refer to the instructions for your scanning or document management software application.

Clearing Paper Jams in the ADF

If a paper jam occurs in the ADF (Automatic Document Feeder), the jam is often the result of loading torn documents, documents with thin paper, or documents that are creased or curled on the edge going into the feeder. For information on how to prepare documents for scanning with the ADF, see [“Document Preparation” on page 52](#). If you have difficulty when scanning documents with the ADF, use the flatbed.

If a paper jam occurs, remove the jammed sheet or sheets using one or both of the following procedures:

Removing Paper Jams from the Document Feeder



Caution

Do not attempt to pull out jammed paper with the ADF door closed. This action may damage the document.

- 1 Push the ADF door release button to open the ADF door.

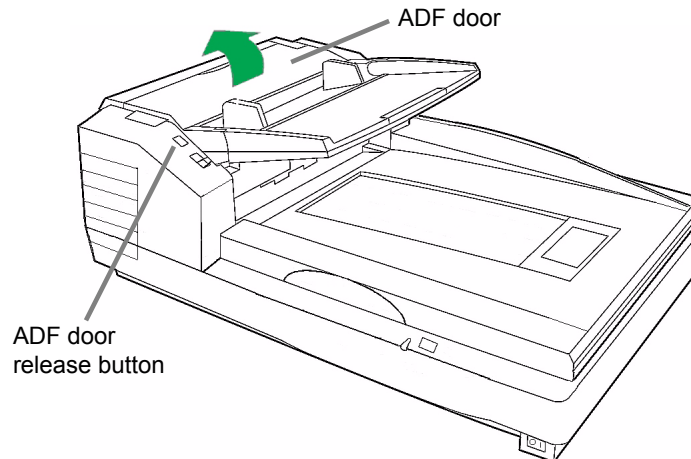

- 2** Pull the jammed document out of the document feeder.

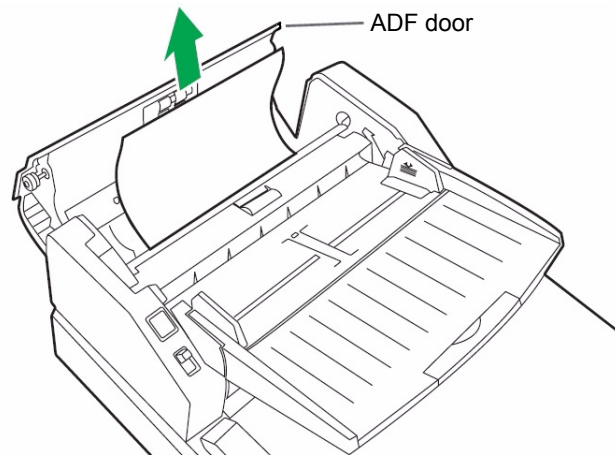

When only the bottom end of jammed paper is visible with the ADF door open, keep the ADF door open and also open the exit door. Carefully remove the jammed paper through either the document feeder or the exit path, as described in [“Removing Paper Jams from the Exit Path” on page 61](#).

- 3** Close the ADF door.
- When you close the ADF door, close it securely until the door is locked. Do not slam the ADF door.

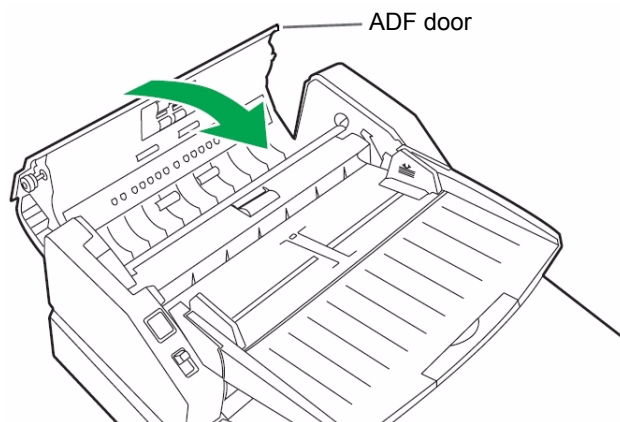

If the jammed paper cannot be removed from the document feeder, remove it from the exit path as described in [“Removing Paper Jams from the Exit Path” on page 61](#).

Removing Paper Jams from the Exit Path

- 1** Pull the exit stopper forward and raise the feeder tray in the direction of the arrow until the tray clicks into place.

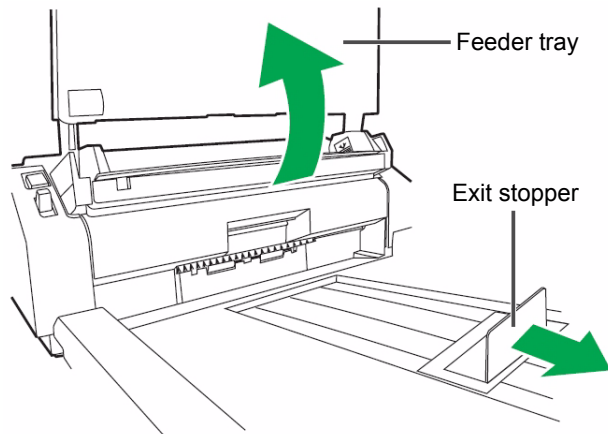

- 2** Pull the exit door release lever and open the exit door.

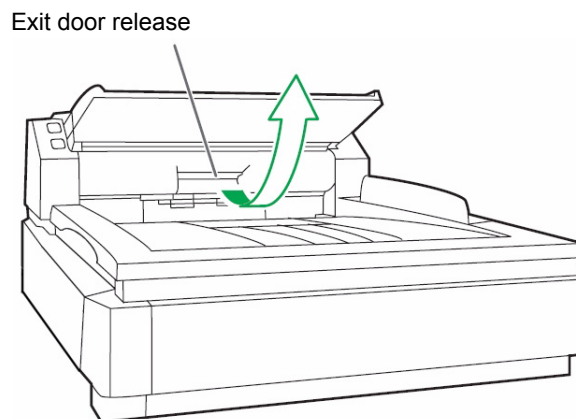

3 Pull out the jammed document from the exit area.

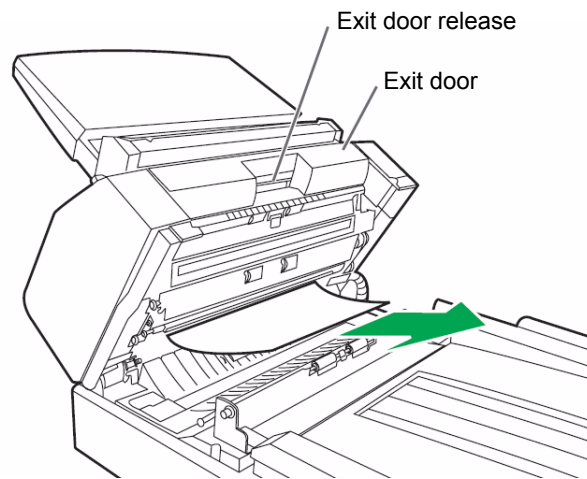

4 Close the exit door.

- When you close the exit door, close it securely until the door is locked. Do not slam the exit door.

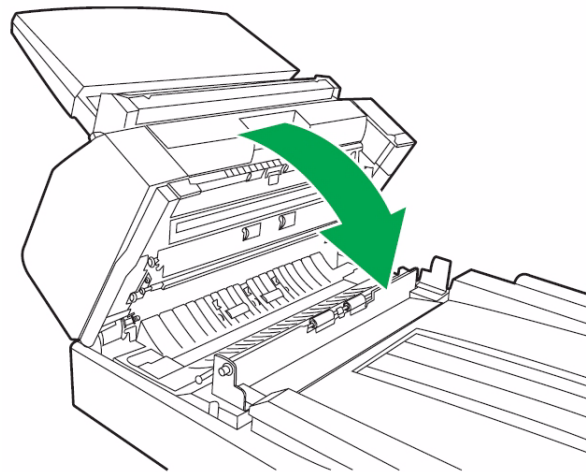

If the jammed paper cannot be removed from the exit door, remove it from the document feeder as described in [“Removing Paper Jams from the Document Feeder” on page 59](#).

STOP/START Button Operation

The scanner STOP/START button has different functions depending on the mode of operation.

Emergency Stop mode (default)

If the scanner is running and feeding paper, press the blue STOP/START button to immediately stop the paper in the scanner. This is the default mode of operation.

Follow the [Clearing Paper Jams](#) steps to remove the paper jammed in the scanner.

Feed Modes with the ADF

If the scanning application supports the *Advanced Scanner Settings*, the scanner can be configured in either automatic, manual or wait for start feed modes via operator selection of the *Advanced Settings - Manual Feed Mode*.

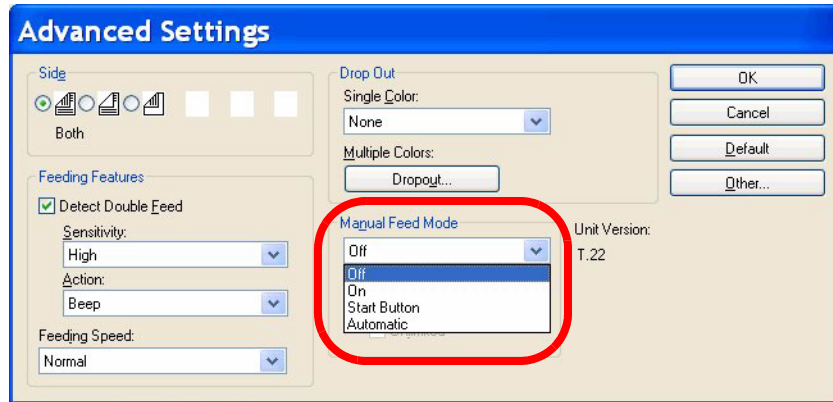

Note

The Timeout indication is active in all Manual Feed Mode options except for “Off”. This feature sets the time between the end of the scanned batch and the “out of paper” indication. The value is in seconds, ranging from 1 to 300, with the default set to 30 seconds.

Automatic Document Feeding (Default Mode)

This is the standard mode of operation. In this mode, immediately after a batch has been scanned, the “out of paper” indication appears.

- Select **Off** from the **Manual Feed Mode** drop-down list.
- Load the documents in the scanner and click the **Start Batch** button (or button with similar name) in the scanning application to start scanning the batch of documents from the application. The scanner paper feed rollers will automatically start and stop to feed the documents in the scanner.

Manual Feed

Use this mode when feeding mixed document types that are difficult to separate and typically cause multifeed problems. In this mode, the ADF tray is continuously raised and the feeder rollers are not engaged until the document’s leading edge approaches the feeder roller.

1. Select **On** from the **Manual Feed Mode** drop-down list.
2. Click the **Start Batch** button (or button with similar name) in the scanning application and start manually feeding the batch of documents one by one in the feed rollers. As the lead edge of a document comes close to the feed rollers, the paper feed rollers will automatically start and feed the document in the scanner.
3. To exit the Manual Feed Mode, press the scanner’s STOP/START key and cancel scanning from the application.

Wait for Start to Feed

In this mode, the operator can manually control the start and stop of a batch using the STOP/START button. To exit the feed mode, press the scanner's STOP/START key and cancel scanning from the application.

1. Select **Start Button** from the **Manual Feed Mode** drop-down list.
2. Click the **Start Batch** button (or button with similar name). The scanner will not start feeding as it is waiting for the STOP/START button.
3. Load the document(s) under the paper feed roller.
4. Press the STOP/START button to begin scanning
The scanner will start scanning and will continue until the feeder is empty or the operator presses the STOP/START button to stop the batch.
5. During the scan operation, press the STOP/START button to stop scanning. This is not an emergency stop. The scanner will complete scanning of the document and then stop prior to feeding the next document.

With this setting activated, the operator manually controls the scanner start and stop document feed operation. Continue steps 2, 3 and 4 until you are ready to close your batch with the scanning application.

Automatic Start to Feed

Use this mode to drop the ADF tray between each batch and to restart scanning immediately.

1. Set the feed selector switch to AUTOMATIC. The feeder will adjust automatically to the automatic feed position.
2. Click the **Start Batch** button (or button with similar name) in the scanning application. Place your documents into the feeder tray. As the lead edge of the document batch comes close to the feed rollers, the ADF tray will come up and the paper feed rollers will automatically feed the batch of documents in the scanner.

Scanner Manual Feed Setting

You can use the ADF (Automatic Document Feeder) to scan a document one sheet at a time. This setting is not recommended for multiple or batch feeding; the bottom feeder roller is dropped, making it easier to scan thicker documents through the ADF.

To scan a single sheet manually, perform the following procedure:

- 1** Set the feed selector switch to MANUAL. The feeder will adjust automatically to the manual feed position.

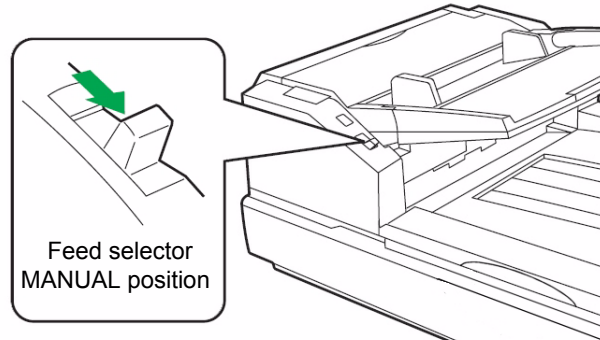

- 2** Adjust the document guides so that the space for the document is slightly wider than the size of the document.

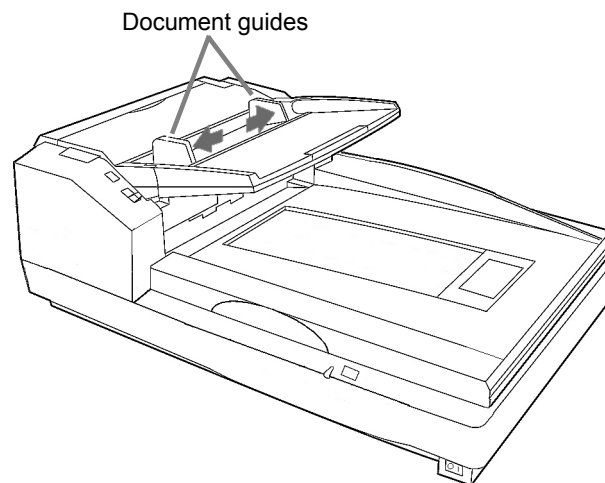

- 3** Insert one sheet of the document into the paper slot with the side to be scanned facing up.
- To scan in portrait mode, insert the sheet with the top edge going first into the paper slot.
 - To scan in landscape mode, insert the sheet with the left edge going first into the paper slot.
 - See also the document loading diagrams on [page 58](#).

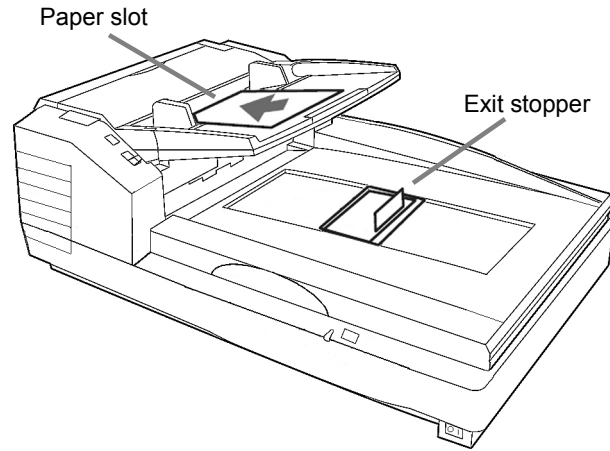

Now that your scanner has been set for Manual Mode, you can adjust the ADF feeding mode by changing the scanner settings as described on [page 64](#).

Feeding Speed

When scanning thin paper, badly creased paper, fragile paper, etc. use the Slow mode. This speed slows the documents that are fed through the ADF (Automatic Document Feeder) to about one-half the speed of Normal mode. The image quality in the Slow mode is the same as in the Normal mode.

Note

At a resolution above 300 dpi, the paper is fed at the same speed as in the Normal mode even if the Slow mode has been specified.

This function cannot be used with flatbed scanning.

1. Navigate to your scanning application and select **Settings**.
2. Click the **More** button in the Settings dialog box.

3. Select a speed from the **Feeding Speed** drop-down list in the Advanced Settings dialog box.

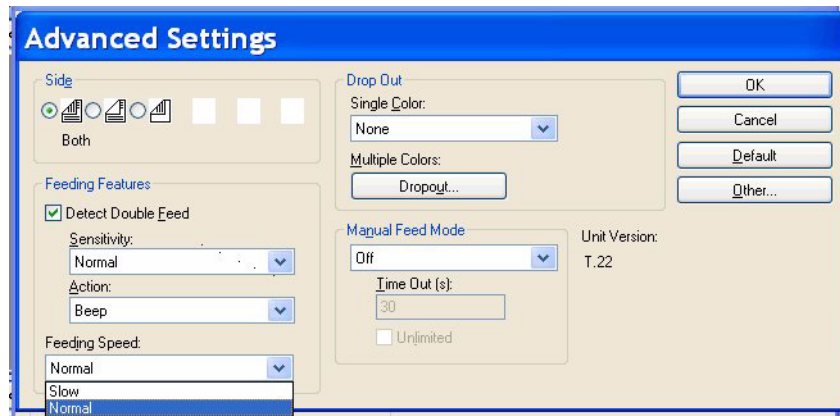

Detect Double Feed

This function detects the feeding of more than one sheet at a time. If a double feed is detected, you can opt to be notified. The default setting for this function is stop.

Note

With this function, ultrasonic waves are aimed at the document to detect double feed by the level at which the waves pass through the sheets. The function can detect double feed even when sheets are superimposed exactly on top of each other, but it may not be detected properly with some paper thicknesses and when creasing and other factors are present.

When important documents are to be scanned, check the number of document sheets and the number of scanned image sheets.

When scanning a document containing paper in different sizes, double feed can be detected when this function is selected.

The default for Detect Double Feed is ON.

1. Navigate to your scanning application and select **Settings**.
2. Click the **More** button in the Settings dialog box.
3. Select the **Detect Double Feed** button in the **Feeding Features** section of the Advanced Settings dialog box.

4. If the Detect Double Feed function operates incorrectly, adjust the sensitivity level by selecting one of the levels in the **Sensitivity** drop-down list.

High	Select this when feeding thin documents.
Normal	This is the standard sensitivity.
Low	Select this when feeding thick documents.

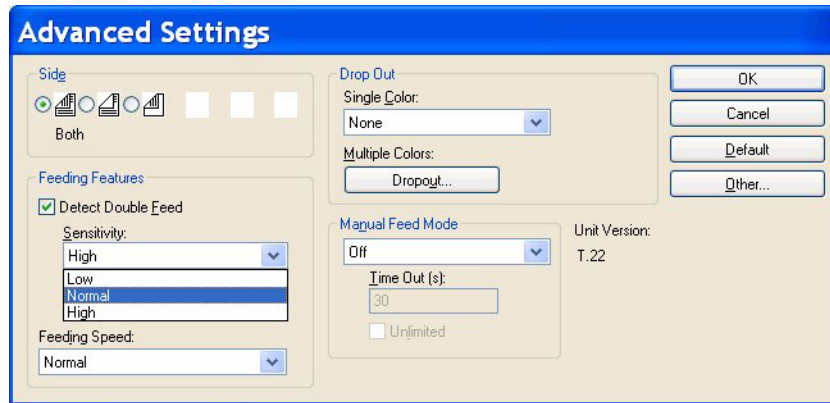

5. Select one of the following from the **Action** drop-down list:

Beep	Signal alert
Stop Scanning	Stops the scanning process for operator attention. This is the default setting.

Using the Flatbed

You can use the Trüper flatbed to scan a single sheet or to scan material that you do not want to take apart before scanning. For example, you can use the flatbed to scan the pages of an open book. Scanning documents in this way is known as “scanning with the flatbed.”



Caution

Do not place floppy disks or any items containing magnetic media on the flatbed. The flatbed sheet contains magnets that may damage data stored on floppy disks or magnetic media.

1 Raise the feeder tray in the direction of the arrow until the tray clicks into place.

2 Open the document cover in the direction of the arrow.

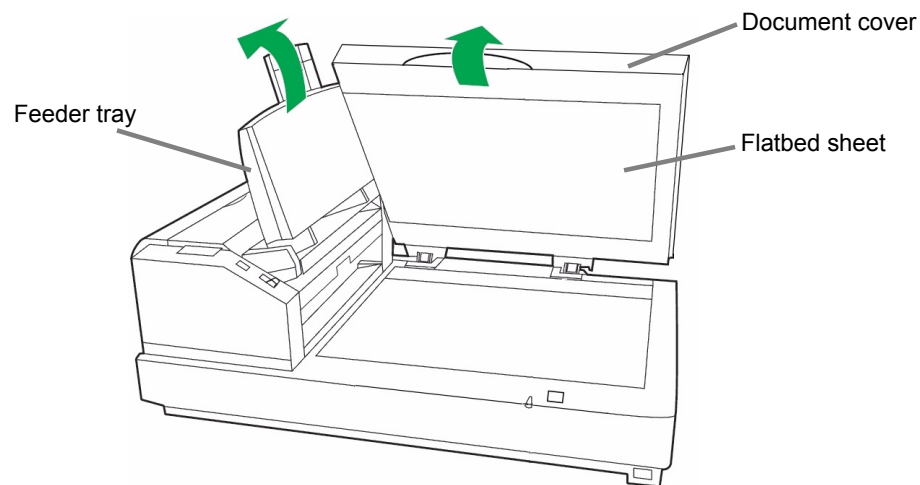

3 In the scanning application, select **Flatbed Mode**.

4 Place the side of the document that you want to scan face down on the surface of the flatbed glass as shown in the following steps and diagrams.

1. Place the document in the upper left corner of the glass. If the document is bent or folded, straighten the document.

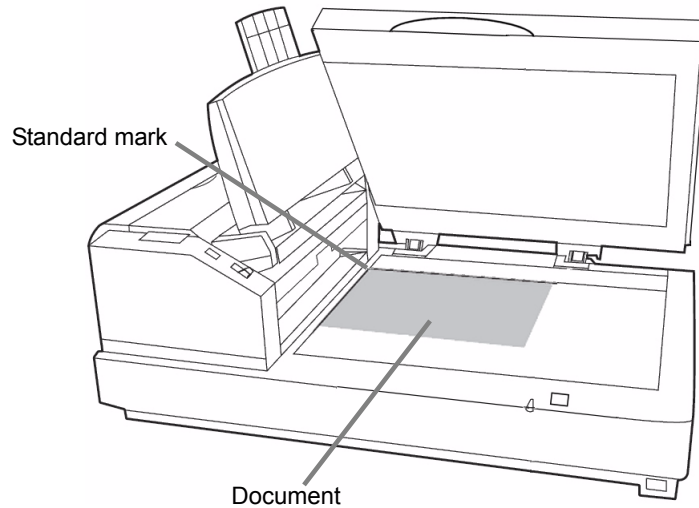

2. Place the shorter edge of the document along the left edge of the flatbed glass. Match the shorter edge with the standard mark.
3. Place the longer edge of the document along the top edge of the flatbed glass. Match the longer edge with the standard mark.

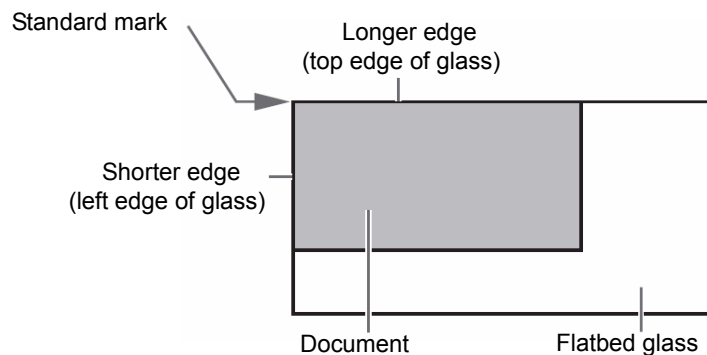

Note

If the document is slanted and not properly aligned along the left and top edges of the flatbed glass, the document will not be scanned properly.

- 5** Close the document cover on top of the document.
- Gently close the document cover and do not slam the cover. If the document cover is slammed, the document may move and may not be scanned properly.
 - Do not open or press down on the document cover during scanning.
 - Be sure to close the document cover before scanning and do not look directly at the scanner light. You may damage your eyes.

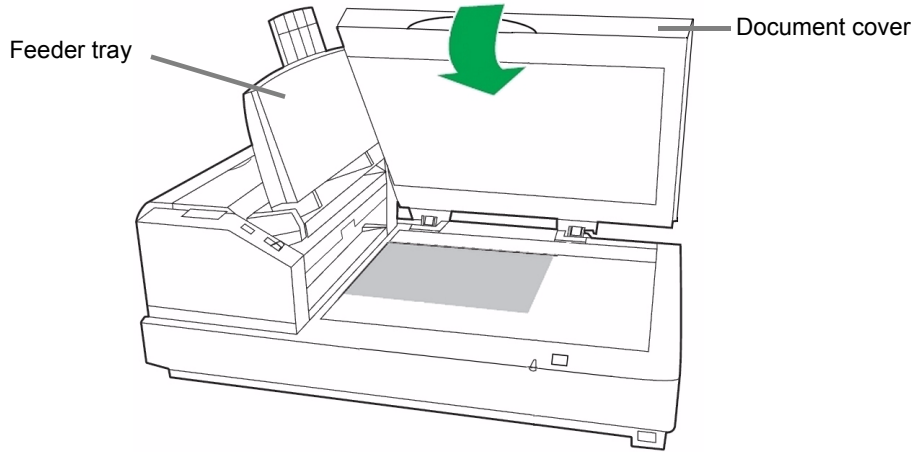

- 6** After scanning, open the document cover and remove the document.

- 7** Do the following to configure the driver:
- Open the Scanner Properties window.
 - Select **Flatbed** from the **Source** drop-down list and click **OK**.

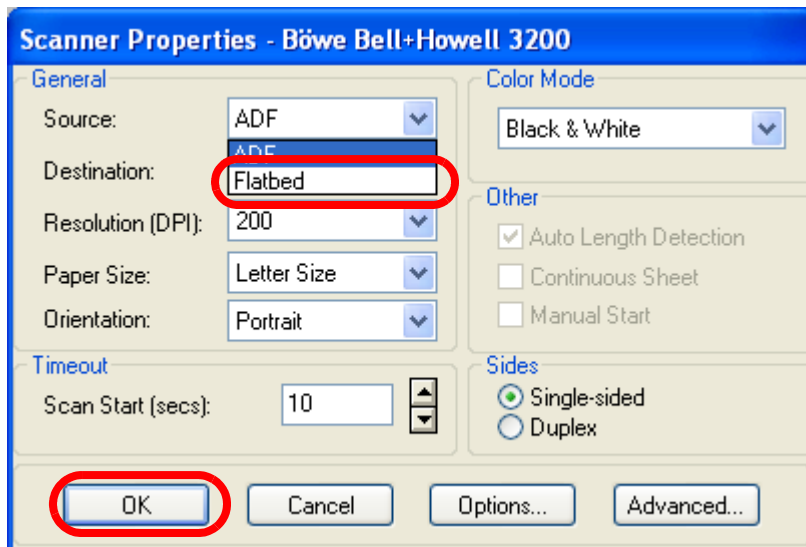

You are now ready to scan. Refer to the instructions for your scanning or document management software application.

Scanning Thick Documents

When scanning thick documents, such as a book in its binding, please note:

- Areas of the document that are not touching the flatbed glass will not be scanned properly.
- If the document moves during scanning, the document will not be scanned properly.

Repeated Use of the Flatbed

When using flatbed scanning for a series of documents, keep the feeder tray raised. You only need to raise and lower the document cover as you scan each document.

Changing the Background Color

You can select the background reference color for the documents you scan. The background reference color is the color of the plate that is behind the document. Depending the type of document being scanned and the features of your scanning application, the background color is important because it may affect the cropping quality of the scanned image. For example, when VRS is selected, crop filters may not work properly if the black background is not selected. In addition, the white background color may affect the use of other scanning features that need to be resolved within the scanning applications feature settings.

The default background color has been set to black. You can set the background color to white or black. To change the background color, change the color reference plates and then change the flatbed sheet to match the color selected with the reference plates. Follow the procedures in the next two sections.

When you change the background color, you must also perform shading adjustment as described in [“Appendix 3—Shading Adjustment” on page 141](#).

Changing the Background Color Reference Plates

- 1** Press the power switch to the OFF position.
- 2** Pull the exit door release lever to open the exit door.

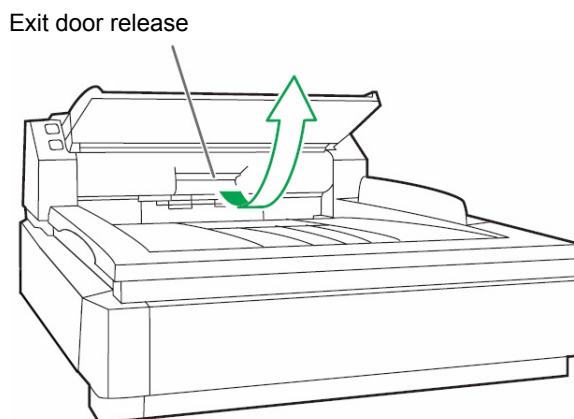

- 3** Locate reference plate (A). Use your finger to turn over reference plate (A) and select the black or white side.

Confirm that the reference plate has been turned over and is locked in position.

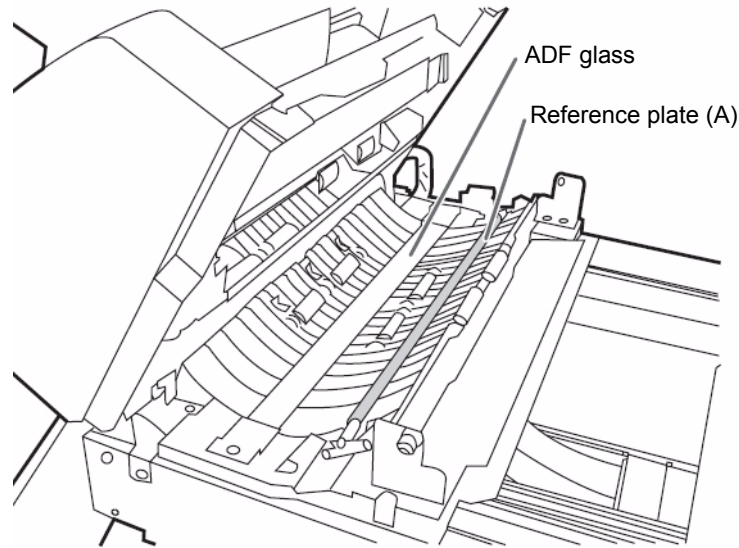

- 4** Locate reference plate (B). Using your finger, turn over reference plate (B) and select the color you want for the background.

Confirm that the reference plate has been turned over and is locked in position.

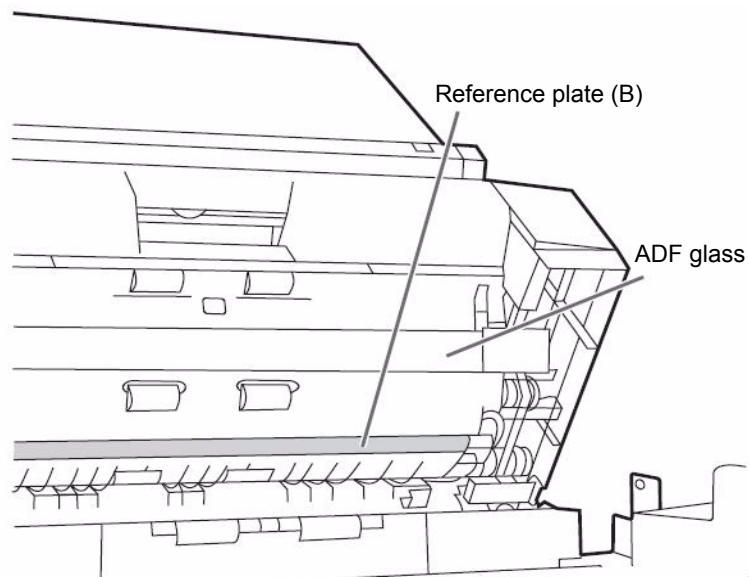

The color selected for reference plate (B) should now match the color selected for reference plate (A).

- 5** Close the exit door.
- When you close the exit door, close it securely until the door is locked. Do not slam the exit door.

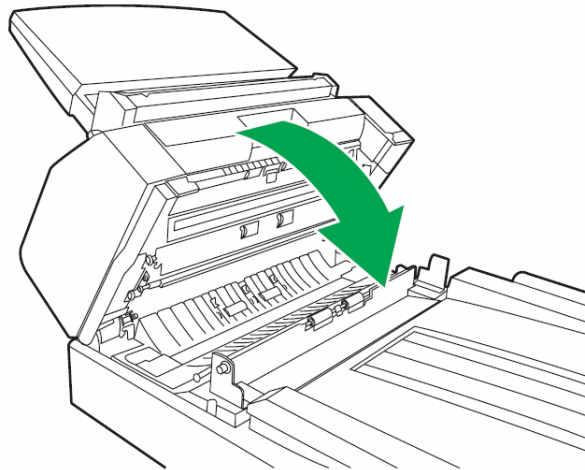

Changing the Background Color with the Flatbed Sheet

To provide a background color, the flatbed sheet is black on one side and white on the reverse side. The flatbed sheet color is initially set to black. You can set the color to white or black. To change the color of the flatbed sheet, perform the following procedure:

- 1** Press the power switch to the OFF position.
- 2** Raise the feeder tray in the direction of the arrow. The feeder tray will click into place in the upright position.
- 3** Open the document cover in the direction of the arrow.

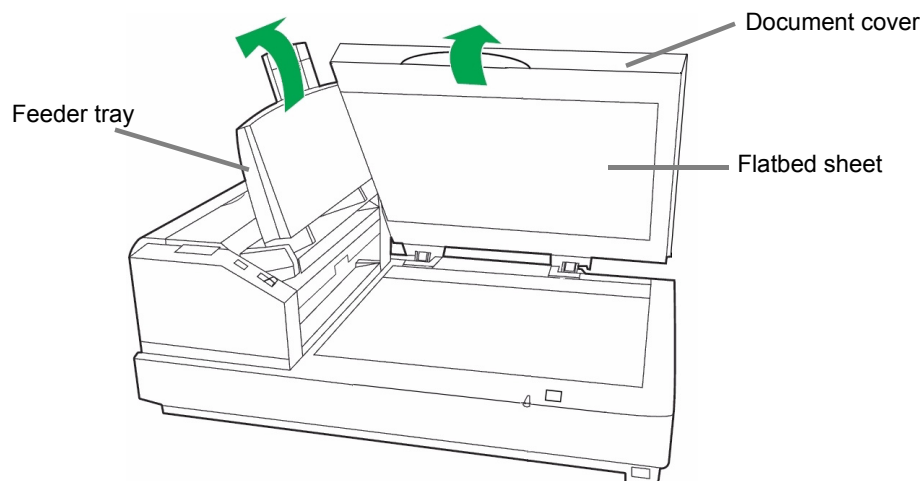

- 4** Gently pull the flatbed sheet away from the document cover. The flatbed sheet is mounted in brackets located on the document cover. The flatbed sheet is attached to the brackets with magnets embedded in the sheet.
- 5** Turn the flatbed sheet over so that the color you want for the background faces the flatbed glass, then re-attach the sheet to the document cover by positioning the corners of the sheet in the brackets.

Operator Maintenance

Cleaning the Outside of the Scanner

To maintain the scanner's performance, clean the outside of the unit at least once per month using the following procedure:

- 1** Press the power switch to the OFF position.

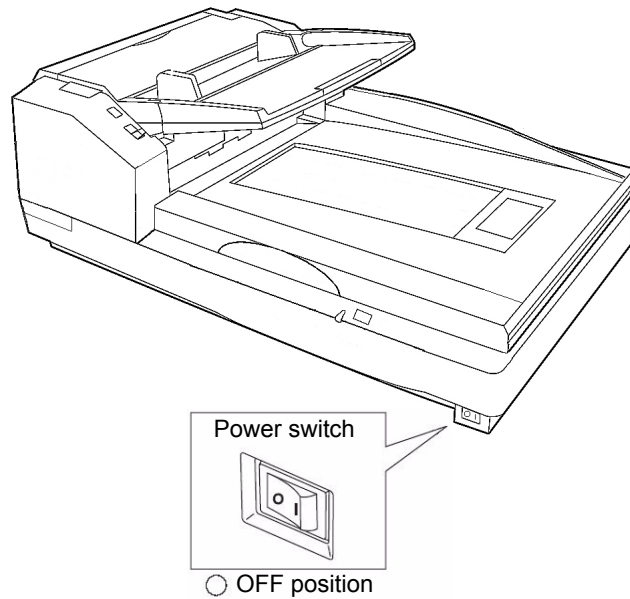

- 2** Clean the exit tray, the feeder and feeder tray, ADF cover and other surfaces with a soft cloth.
- 3** The insertion and exit slots of the ADF can become soiled with dirt, grime and paper dust. Clean these areas at least once per month or more often if there is an accumulation dust.
- 4** Use a brush to remove dirt and dust from the exhaust fan vent on the back side of the unit near the power cord connection and from the two vents on the left and right sides of the ADF assembly.

Cleaning Inside the Scanner

If paper jamming, marking, or multiple-sheet feeding occurs frequently, clean the rollers, sensors and double feed detector as described in this section. To maintain scanning quality, clean the scanner components frequently: Clean inside the scanner at least once per week or after 20,000 sheets have been scanned, whichever comes first.

To determine the number of sheets scanned, use the  Trüper User Utility. (See [“Trüper User Utility” on page 100.](#))

The following guidelines are for cleaning inside the scanner:

- If the documents you scan are dirty, the scanner’s parts and components will also become dirty. Be sure the documents you scan are as clean as possible.
- When scanning with the flatbed, if black dots or white patches appear in the scanned results, open the document cover and clean the flatbed glass and flatbed sheet using the roller cleaning paper.
- If black or white lines appear on the scanned images, clean the ADF glass areas and the reference plates as described in [“Cleaning the Background Color Reference Plates and ADF Glass” on page 87.](#)
- Clean the flatbed glass and document cover detector as described in [“Cleaning the Flatbed Glass and Document Cover Detector” on page 92.](#)
- If paper jamming, marking, or double feeding occurs frequently even after cleaning, you may need to change the rollers, as described in [“Replacing Consumables” on page 94.](#)

Also observe the warnings for use of the roller cleaning paper shown in [“Roller Cleaning Paper” on page 80.](#)

Note

For proper cleaning and maintenance, it is recommended that the following three roller cleaning procedures be performed concurrently.

Roller Cleaning Paper

Use the roller cleaning paper to clean inside the scanner.



Warning

Before using the roller cleaning paper, please read these instructions completely. Keep these instructions for future reference.

- KEEP THE ROLLER CLEANING PAPER AWAY FROM FIRE.
- Do not use the roller cleaning paper near a heater or open flame.
- Do not drink or inhale the roller cleaning paper fluid.
- The roller cleaning paper may be harmful to your skin. Please use protective gloves when working with the cleaning paper.
- Do not store the roller cleaning paper in direct sunlight or in a place with temperature over 104°F (40°C).
- Use the roller cleaning paper only to clean the rollers and scanning area.
- If you need more information about the roller cleaning paper, please refer to the Material Safety Data Sheet (MSDS) available upon request from [Böwe Bell + Howell Scanners](http://www.bbhscanners.com).

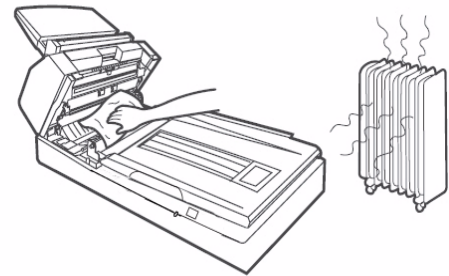

Preparation: Cut the roller cleaning paper bag on the dotted line and take out the roller cleaning paper.

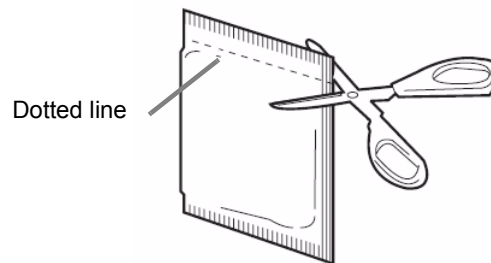

Use the roller cleaning paper immediately after opening the bag. If the bag remains open for a long period of time, the alcohol cleaning solution will evaporate and the cleaning paper will not be effective.

Additional roller cleaning paper is available from the Böwe Bell + Howell Scanning Essentials online store at <http://webstore.bbhscanners.com> or from the reseller where you purchased the Trüper scanner. See also the [“Consumable Parts List” on page 13](#).

Cleaning the Paper Feed Roller, Separation Roller and Retard Roller

1 Press the power switch to the OFF position.

2 Push the ADF door release button to open the ADF door.

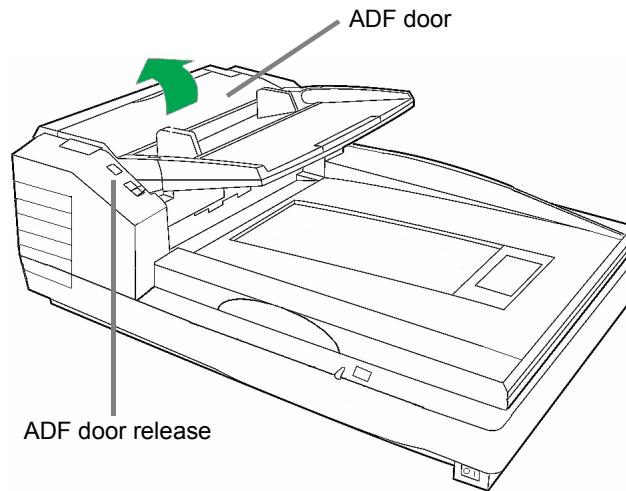

3 Use the roller cleaning paper to remove any dirt or grime from the surfaces of the paper feed roller and separation roller.

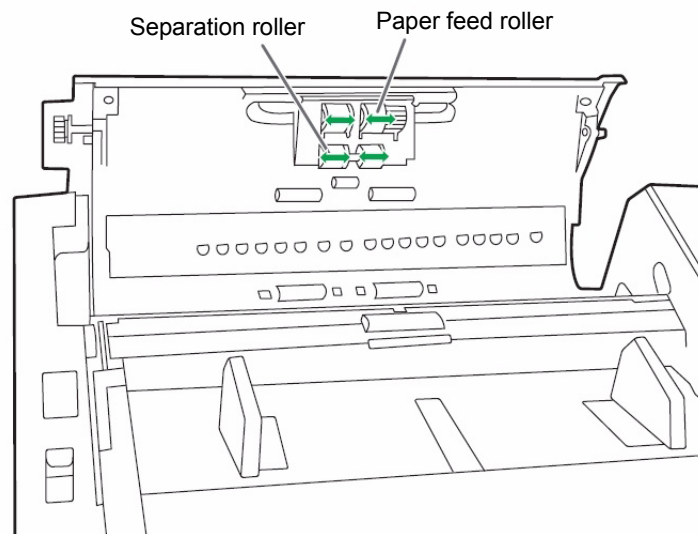

Hold the roller to prevent it from rotating, then wipe the roller from one side to the other in the direction of the arrows shown in the diagram. Turn the roller as you continue to wipe and clean all the way around the roller.

- 4** Open the retard cover in the direction of the arrow shown in the diagram by pulling up from the indent on the right side.

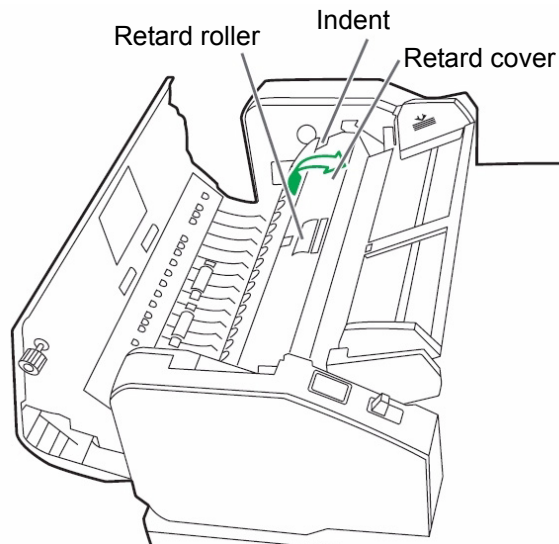

- 5** Use the roller cleaning paper to remove the dirt from the surface of the retard roller.

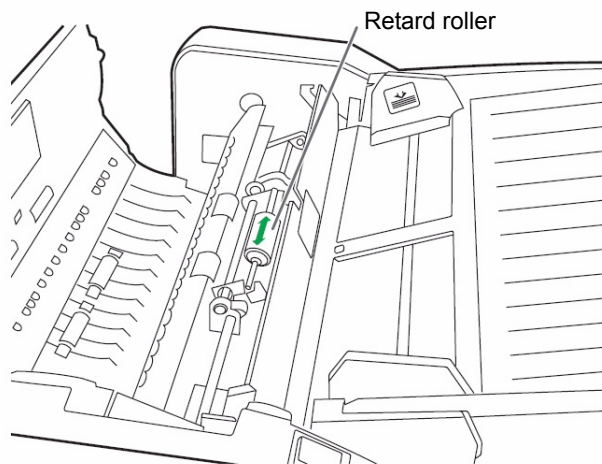

Hold the roller to prevent it from rotating, then wipe the roller from one side to the other in the direction of the arrows shown in the diagram. Turn the roller as you continue to wipe and clean all the way around the roller.

- 6** Close the retard cover in the direction of the arrow as shown in the following diagram.
- When you close the retard cover, close it securely until the cover is locked. Do not slam the retard cover.

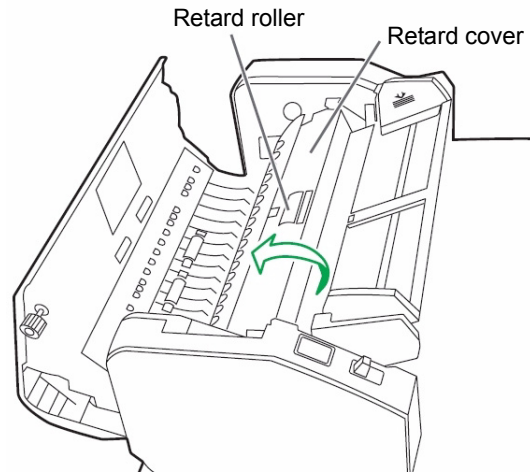

- 7** Close the ADF door.
- When you close the ADF door, close it securely until the door is locked. Do not slam the ADF door.

- 8** Proceed to the following section, “Cleaning the Drive Rollers and Free Rollers in the ADF”.

Cleaning the Drive Rollers and Free Rollers in the ADF

- 1** Press the power switch to the OFF position.
- 2** Push the ADF door release button to open the ADF door.

- 3** Use the roller cleaning paper to remove the dirt from the surfaces of the four (4) drive rollers.

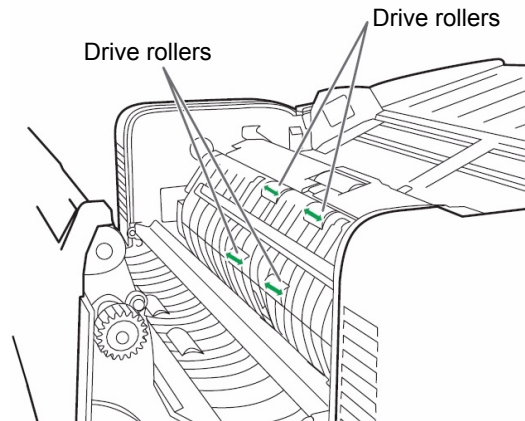

Hold the roller to prevent it from rotating, then wipe the roller from one side to the other in the direction of the arrows shown in the diagram. Turn the roller as you continue to wipe and clean all the way around the roller.

- 4** Use the roller cleaning paper to remove the dirt from the surfaces of the four (4) free rollers.



Hold the roller to prevent it from rotating, then wipe the roller from one side to the other in the direction of the arrows shown in the diagram. Turn the roller as you continue to wipe and clean all the way around the roller.

- 5** Close the ADF door.
- When you close the ADF door, close it securely until the door is locked. Do not slam the ADF door.
- 6** Proceed to the following section, “Cleaning the Drive Rollers, Free Rollers and Exit Rollers in the Exit Door”.

Cleaning the Drive Rollers, Free Rollers and Exit Rollers in the Exit Door

- 1** Press the power switch to the OFF position.
- 2** Pull the exit door release lever to open the exit door.

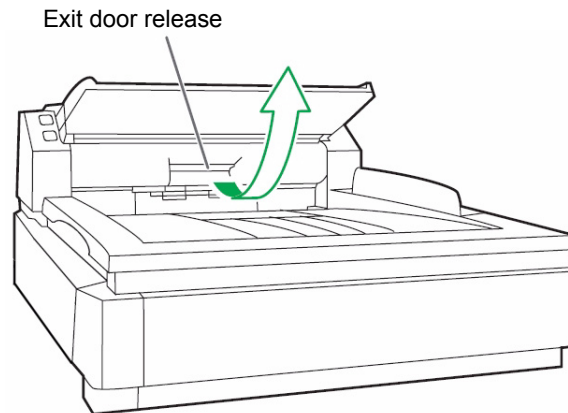

- 3** Use the roller cleaning paper to remove the dirt from the surfaces of the four (4) drive rollers and the two (2) exit rollers.

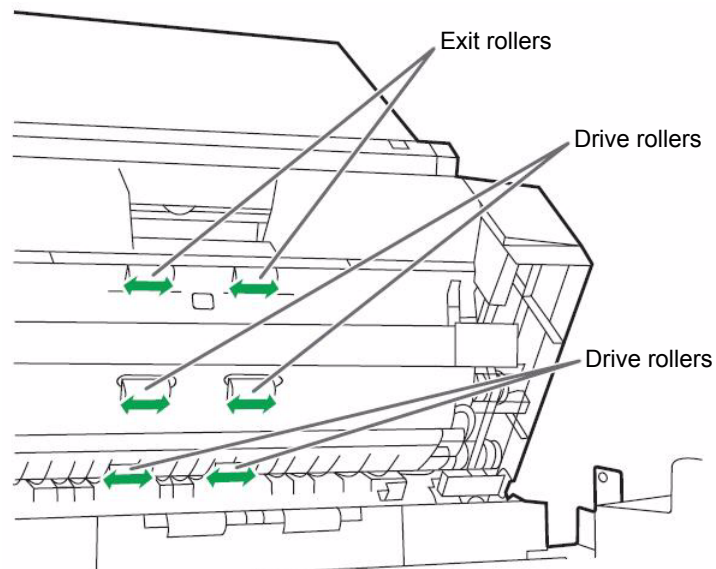

Hold the roller to prevent it from rotating, then wipe the roller from one side to the other in the direction of the arrows shown in the diagram. Turn the roller as you continue to wipe and clean all the way around the roller.

- 4** Use the roller cleaning paper to remove the dirt from the surfaces of the six (6) free rollers.

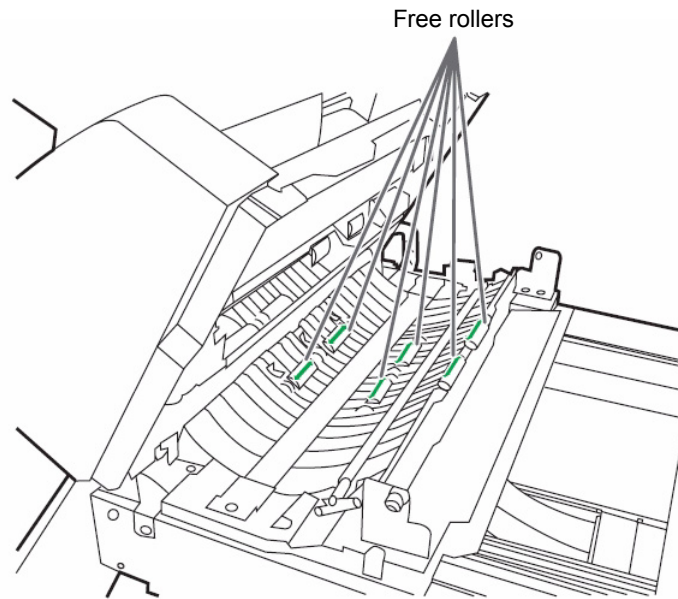

Hold the roller to prevent it from rotating, then wipe the roller from one side to the other in the direction of the arrows shown in the diagram. Turn the roller as you continue to wipe and clean all the way around the roller.

- 5** Close the exit door.
- When you close the exit door, close it securely until the door is locked. Do not slam the exit door.

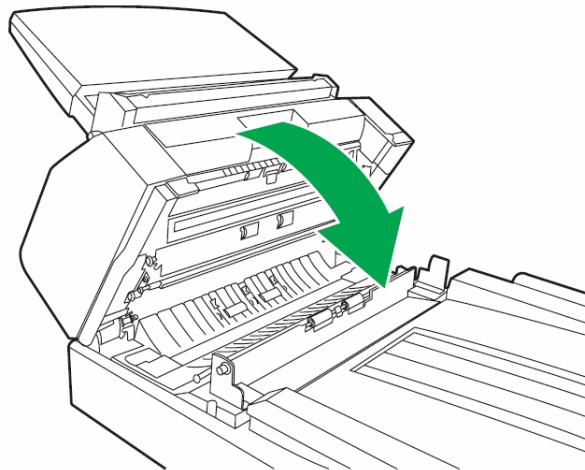

When finished, clear the clean roller counter as described in step 6.

- 6** After cleaning the rollers, click the  icon to open the Trüper User Utility. Select the User Utility option to clear the roller cleaning counter. See ["Scanner Counter" on page 106](#).

Cleaning the Background Color Reference Plates and ADF Glass

- 1** Press the power switch to the OFF position.
- 2** Pull the exit door release lever to open the exit door.
- 3** In the scanner base assembly, clean the ADF glass (A) and reference plate (B) with the roller cleaning paper.

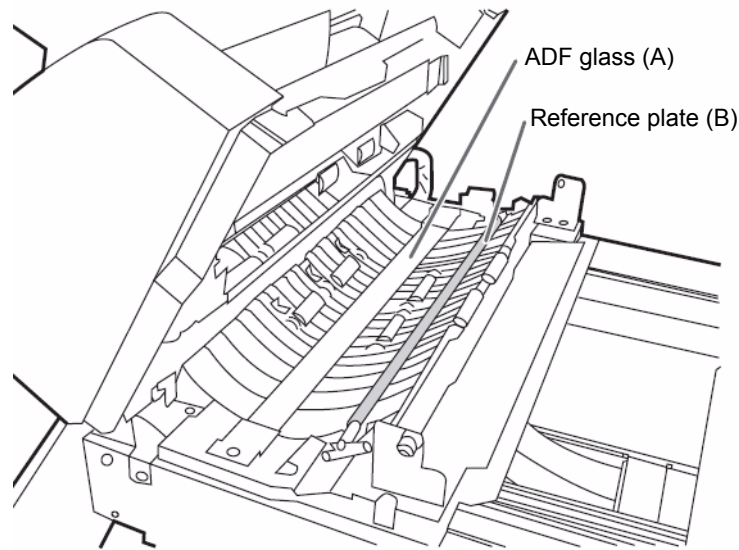

- 4** In the exit door assembly, clean the reference plate (C) and ADF glass (D) with the roller cleaning paper.

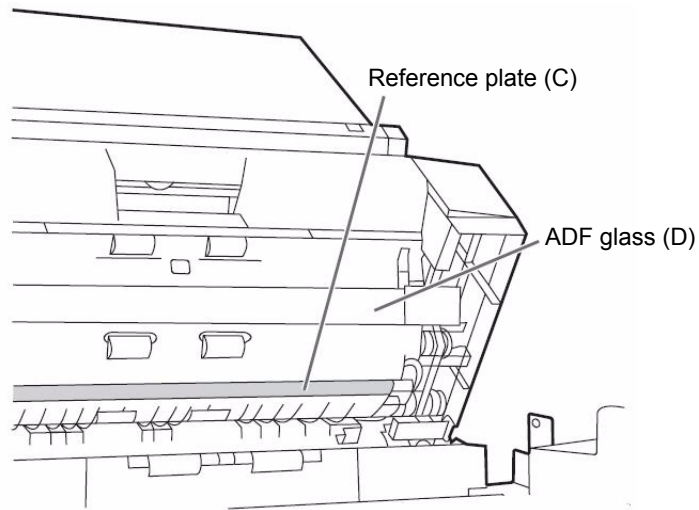

- 5** Close the exit door.
- When you close the exit door, close it securely until the door is locked. Do not slam the exit door.

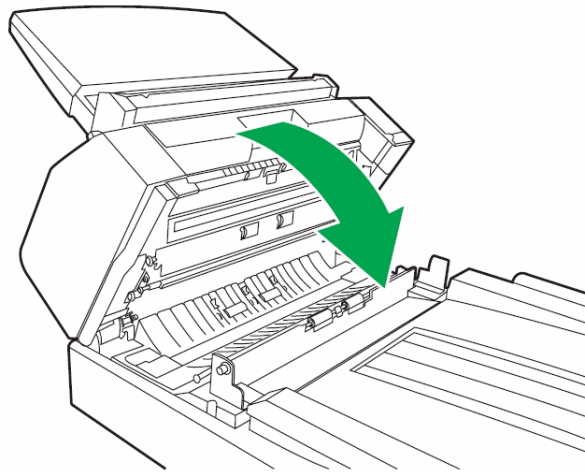

Cleaning the Paper Sensor, Waiting Sensors and Double Feed Detector

Preparation: Locate the blower accessory and remove the brush from the blower.

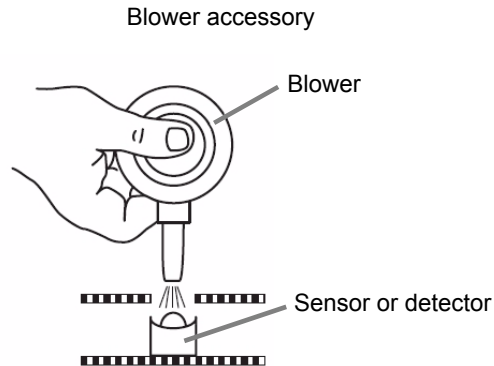

- 1** Press the power switch to the OFF position.
- 2** Push the ADF door release button to open the ADF door.
- 3** Use the blower accessory to blow off any dirt from the surface of the paper sensor and waiting sensor. Also, blow off any dirt from the surface of the metal reflector sheet used by the waiting sensor.

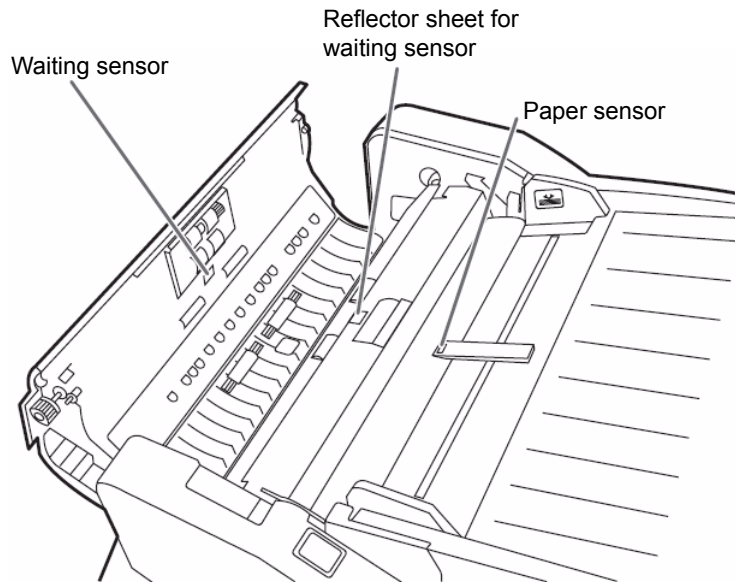

- 4** Use the blower accessory to blow off any dirt from the double feed detector (A) and double feed detector (B).

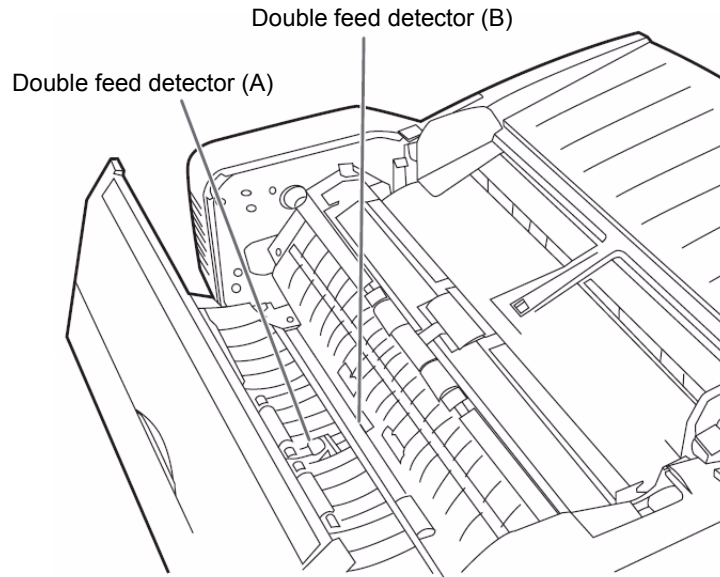

- 5** Close the ADF door.
- When you close the ADF door, close it securely until the door is locked. Do not slam the ADF door.

Cleaning the Starting, Skew and Ending Sensors

Preparation: Locate the blower accessory and remove the brush from the blower.

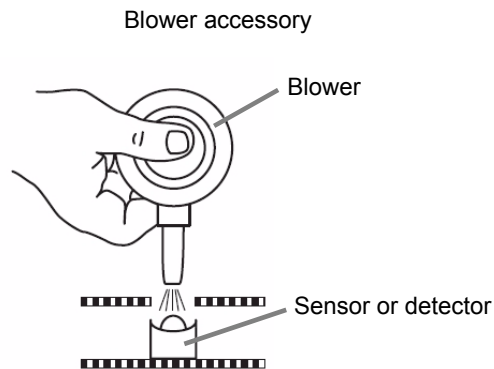

- 1** Press the power switch to the OFF position.
- 2** Pull the exit door release lever to open the exit door.

- 3** Use the blower accessory to blow off any dirt from the surface of the starting sensor, skew sensor (left), skew sensor (right) and ending sensor.

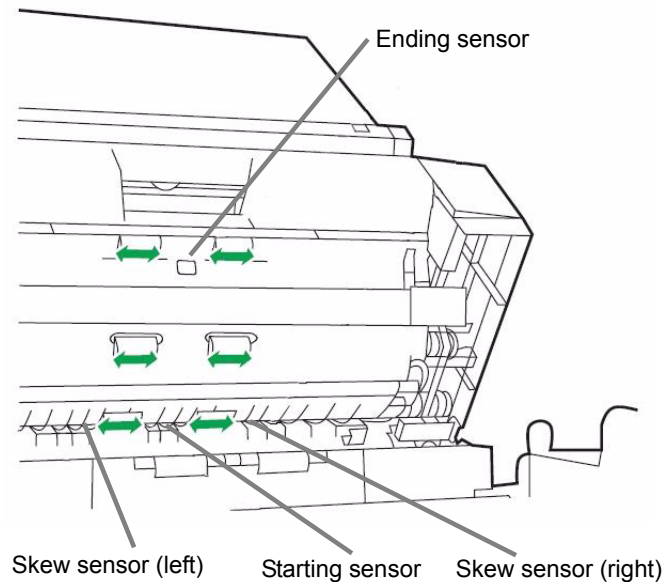

- 4** Use the blower accessory to blow off any dirt from the reflector sheets for the starting sensor, skew sensor (left), skew sensor (right) and the ending sensor.

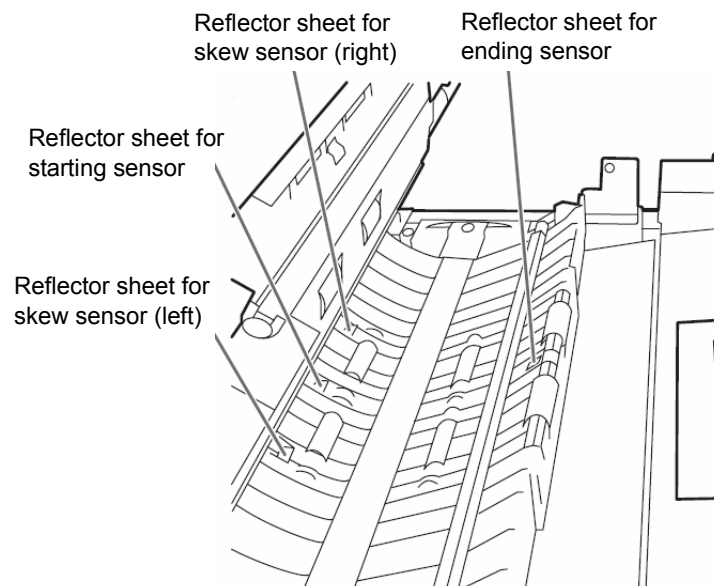

- 5** Close the exit door.
- When you close the exit door, close it securely until the door is locked. Do not slam the exit door.

Cleaning the Flatbed Glass and Document Cover Detector

Preparation: Locate the blower accessory and remove the brush from the blower. Open a package of the roller cleaning paper, as described in [“Roller Cleaning Paper” on page 80](#).

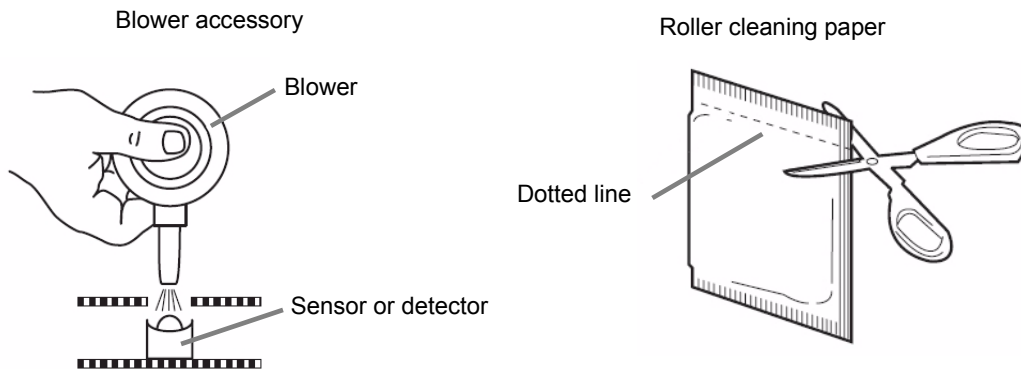

- 1** Press the power switch to the OFF position.
- 2** Raise the feeder tray in the direction of the arrow until the tray clicks into place.
- 3** Open the document cover in the direction of the arrow.

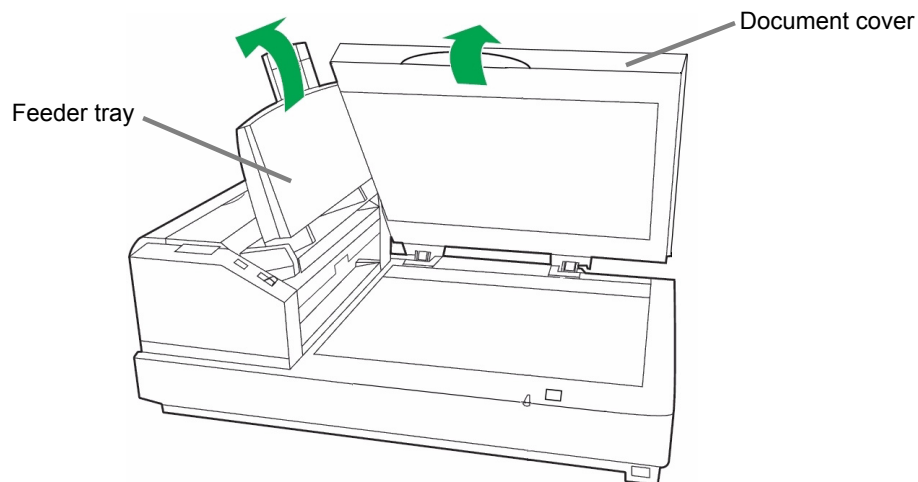

- 4** Clean the surface of the flatbed glass with the roller cleaning paper and remove any dirt. If required, clean the surface of the flatbed sheet.

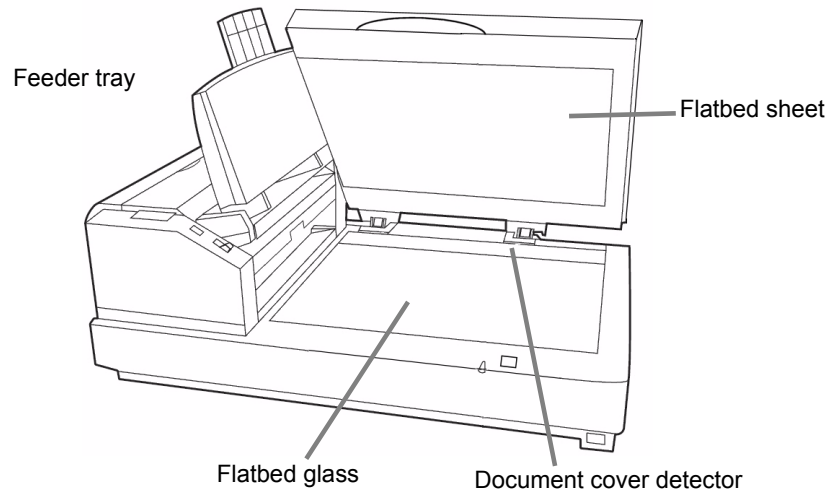

- 5** Use the blower accessory to blow off any dirt that may have accumulated in the area of the document cover detector.

- 6** Close the document cover.
- Gently close the document cover and do not slam the cover.

- 7** Lower the feeder tray to its original position.

Replacing Consumables

Replacing the Paper Feed Roller Module

The Trüper scanner allows you to perform routine maintenance without calling a service technician. This includes replacing a variety of parts that become worn as the scanner is used.

Replace both the feed roller module and the retard roller module after 300,000 scans. Replace the roller modules more often if you find that cleaning inside the scanner no longer improves paper jamming, slipping, multi-feeding, marking and similar feeding problems.

Preparation: Open the Roller Exchange Kit. Roller Exchange Kits are available from the Böwe Bell + Howell Scanning Essentials online store at <http://webstore.bbhscanners.com> or from the reseller where you purchased the Trüper scanner. See also the ["Consumable Parts List" on page 13](#).

- 1** Press the power switch to the OFF position.
- 2** Push the ADF door release button to open the ADF door.

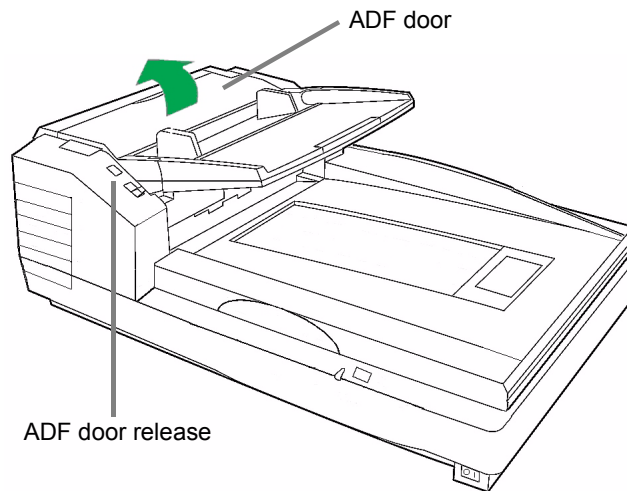

3 Remove the paper feed roller module from the ADF door as shown in the following steps and diagrams.

1. Place your fingers on the tabs on the sides of the roller module and pull down the roller module in the direction of the arrow as shown in the diagram. The module will be released from the magnets located in the ADF door assembly.

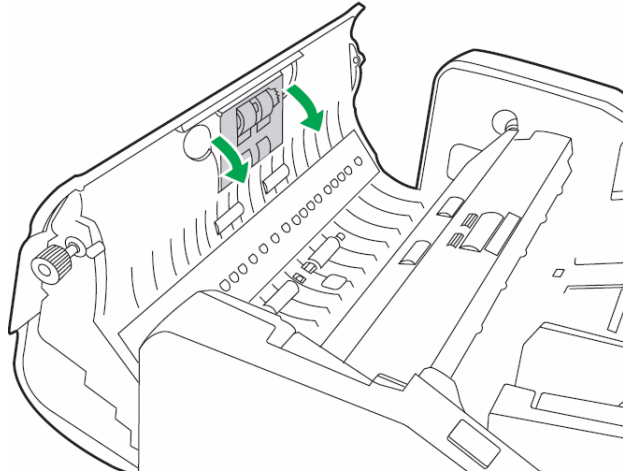

2. Disengage the shaft on the roller module from the brackets in the ADF door assembly as shown in the diagram. Carefully disengage the gears on the roller module from the gears in the ADF door assembly.

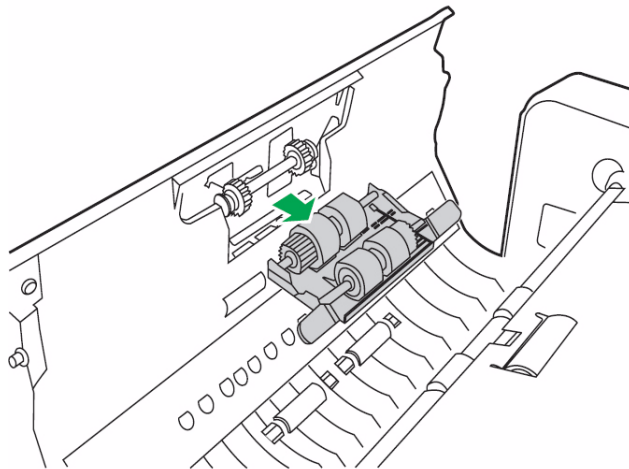

4 Open the Roller Exchange Kit and take out the new paper feed roller module.

5 Install the new paper feed roller module as shown in the following steps and diagrams.

1. Carefully insert the shaft on the roller module into the brackets in the ADF door assembly.
2. Carefully match the gears on the roller module with the gears in the ADF door assembly.

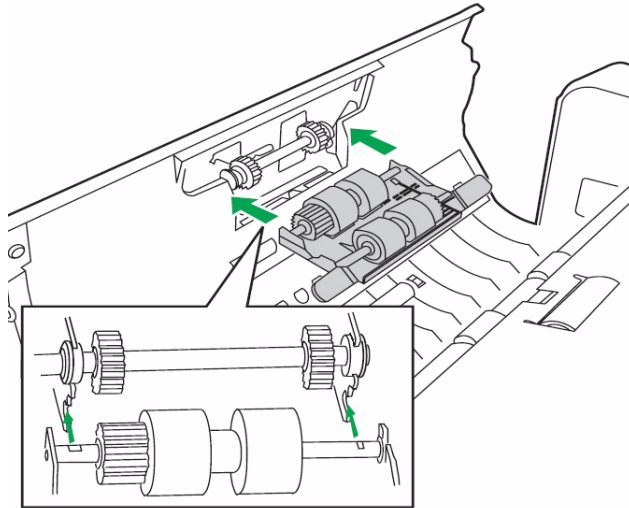

3. Push up the roller module in the direction of the arrow shown in the diagram, so that it is locked in place by the magnets located in the ADF door assembly.

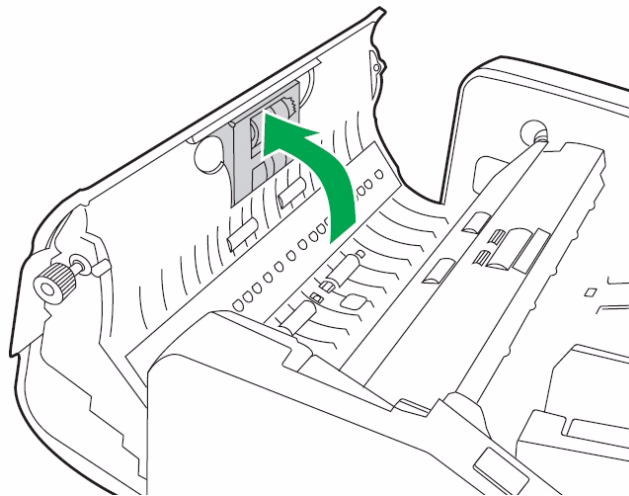

6 Close the ADF door.

- When you close the ADF door, close it securely until the door is locked. Do not slam the ADF door.

Replacing the Retard Roller Module

Replace both the feed roller module and the retard roller module after 300,000 scans. Replace the roller modules more often if you find that cleaning inside the scanner no longer improves paper jamming, slipping, multi-feeding, marking and similar feeding problems.

Preparation: Open the Roller Exchange Kit. Roller Exchange Kits are available from the Böwe Bell + Howell Scanning Essentials online store at <http://webstore.bbhscanners.com> or from the reseller where you purchased the Trüper scanner. See also the "[Consumable Parts List](#)" on page 13.

- 1** Press the power switch to the OFF position.
- 2** Push the ADF door release button to open the ADF door.

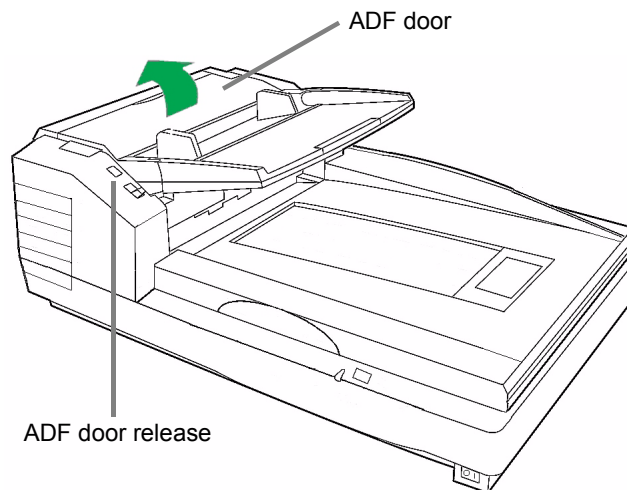

- 3** Open the retard roller cover by pulling up the cover from the right side. Pull the cover in the direction of the arrow marked next to the indented section on the cover.

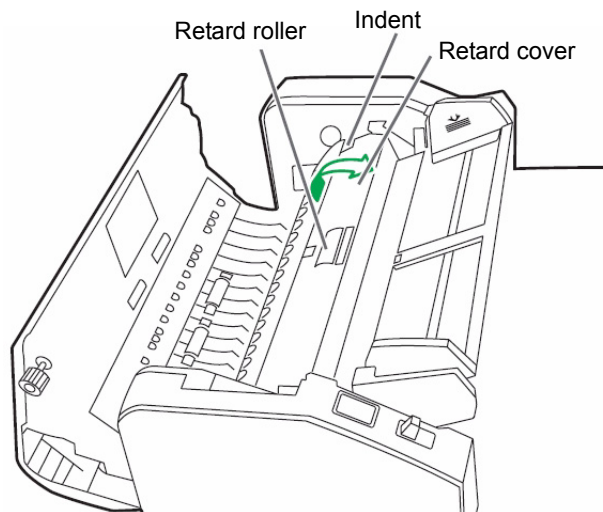

- 4** Remove the retard roller from the metal brackets by holding the ends of the roller shaft and pulling up the roller in the direction of the arrows, as shown in the following diagram.

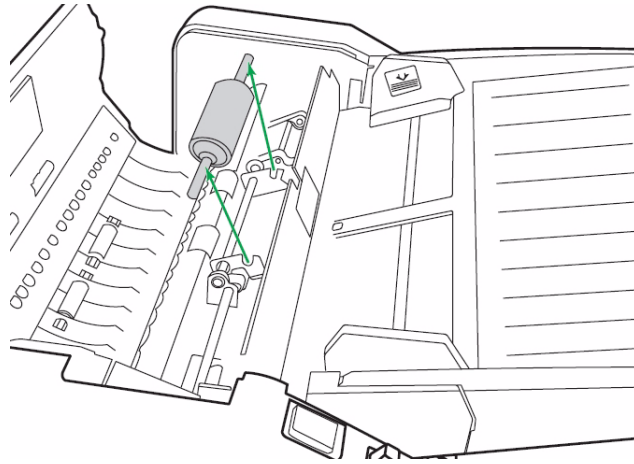

- 5** Open the Roller Exchange Kit and take out the new retard roller.

- 6** Install the new retard roller as shown in the steps and diagram.
1. Hold the ends of the roller shaft and lower the roller into the metal brackets.
 2. Match the groove on one side of the roller shaft with the metal bracket that fits the groove. When the groove is matched with the bracket, the roller shaft slides into the bracket.

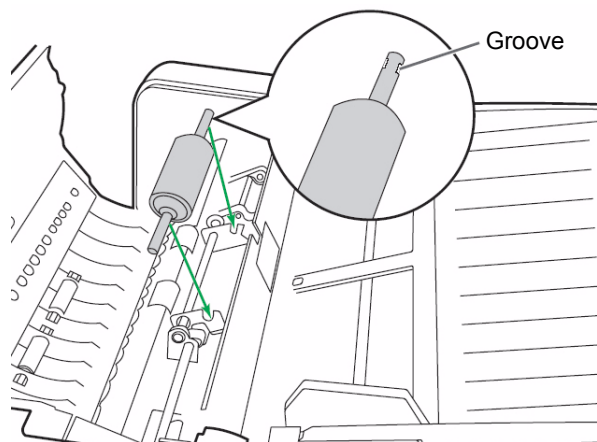

7

Close the retard roller cover.

- When you close the retard cover, close it securely until the cover is locked. Do not slam the retard cover.

After replacing the paper feed and retard roller modules, click the  icon to open the Trüper User Utility. Select the User Utility option to clear the clean roller counter. See [“Scanner Counter” on page 106](#).

8

Close the ADF door.

- When you close the ADF door, close it securely until the door is locked. Do not slam the ADF door.

Trüper User Utility

The Trüper User Utility is a software program used to maintain and troubleshoot the Trüper 3200 scanner. The User Utility is installed as part of the scanner's software installation.

If you do not find the  Trüper User Utility icon on the computer desktop, please see ["Trüper Software Installation" on page 34](#).

Starting the User Utility

Click the  Trüper User Utility icon on the computer desktop, or click the **Start** button on the Windows taskbar and select **Programs**, **BBH**, and then **Scanner Tools**.

Note

When starting the Trüper User Utility, the Select Scanner dialog box may appear. If this dialog box appears, select the **BBH 3200 USB** scanner from the drop-down list.

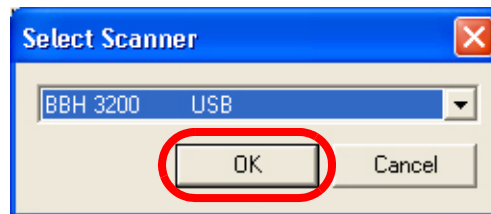

Functions and Settings

User Utility Main Dialog Window

This window displays the scanner status, scanner information and the User Utility functions and settings options.

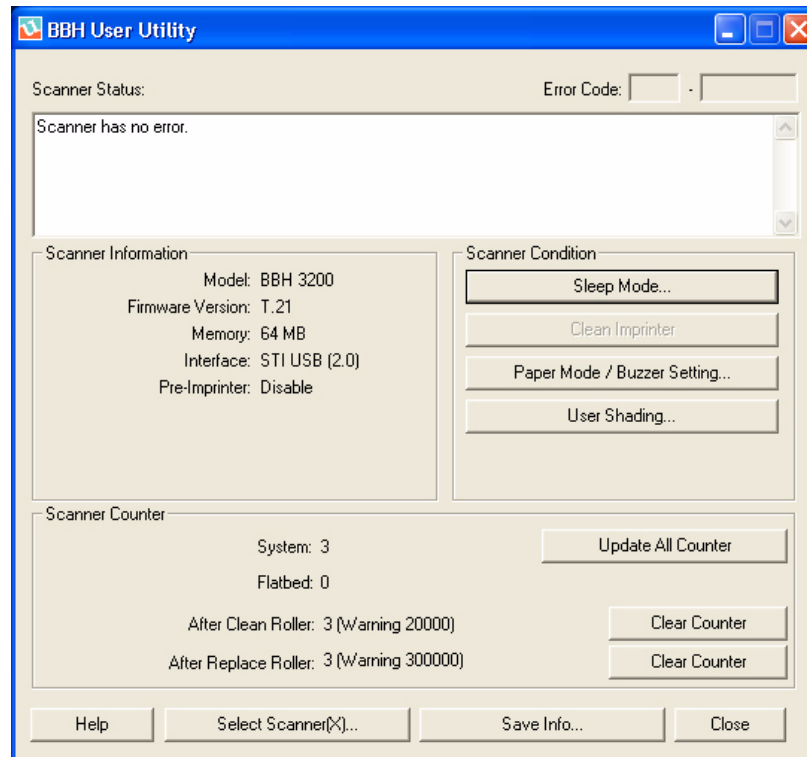

Scanner Status and Error Code Display

This section displays the status of the connected scanner along with error codes. For information about the messages and error codes, see [“User Utility Error Codes” on page 109](#).

Scanner Information

This section displays the following information:

- Model name and number
- Firmware Version
- Memory requirements
- Interface, one of the following:
 - STI USB (HS) = USB 2.0 Hi-Speed (default configuration)
 - STI USB (FS) = USB 1.1 Full Speed
 - ASPI SCSI = SCSI (Invalid configuration. No ASPI driver included.)
 - STI SCSI = SCSI (Using installed scanner driver.)
- Pre-Imprinter, enable or disable

Sleep Mode

To conserve energy and reduce operating costs, the scanner has a programmable power save feature. The scanner's factory setting is as follows: The power save feature is enabled with a waiting time of 15 minutes, so that the Sleep Mode goes into effect after 15 minutes after the last scanner operation. This setting complies with ENERGY STAR requirements.

Click the **Sleep Mode** button to change the settings:

- When the **Sleep Mode** check box is selected, the Sleep Mode is enabled. To disable this feature, clear the check box next to **Sleep Mode**, then click **OK**.
- To change the waiting time until the Sleep Mode goes into effect, be sure the Sleep Mode check box is selected, adjust the minutes in the **Waiting Time** box, then click **OK**. (The waiting time can be set from one to 60 minutes in one-minute increments.)
- If you do not want to change the settings, click **Cancel**.

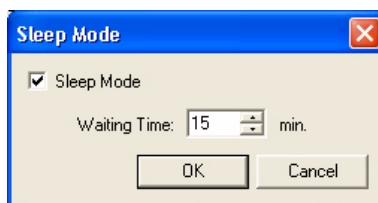

Clean Imprinter

The Clean Imprinter button is enabled only when the imprinter is installed in the scanner. If the imprinter ink cartridge is clogged, first close the imprinter door, then click the **Clean Imprinter** button to clean the cartridge. The unit will perform an automatic cleaning function to improve the print quality.

Paper Mode/Buzzer Setting

The scanner can alert you with a buzzer when it detects a designated paper size. Click the **Paper Mode/Buzzer Setting** button to change the settings:

- In the Paper Mode section, select the size of paper to be detected by the paper guides: **A4** or **Letter** size.
- In the Buzzer Setting section, select **ON** or **OFF**, then click **OK**.
- If you do not want to change the settings, click **Cancel**.

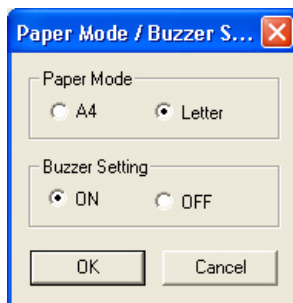

User Shading

The User Shading function provides adjustments to improve image quality. Perform shading adjustment if the image quality has deteriorated and does not improve even after cleaning inside the scanner. To perform shading adjustment, you will need a sheet of the special shading paper that is included with the scanner. See also [“Appendix 3—Shading Adjustment” on page 141.](#)

1. Click the **User Shading** button on the User Utility window.
2. Click the **Start Shading** button on the User Shading dialog box. The User Shading utility will guide you through the necessary steps.

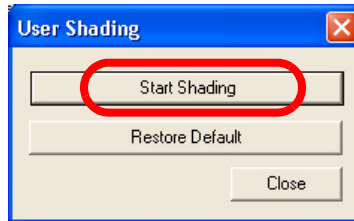

3. Clean the inside of the scanner, refer to [“Cleaning Inside the Scanner” on page 79.](#) When finished, click **OK**.

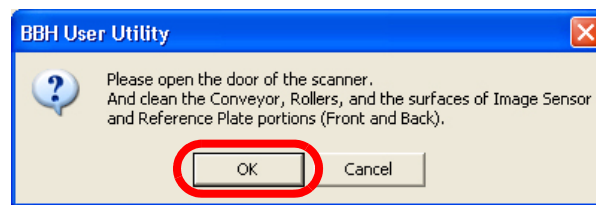

4. Turn over both the front and back reference plates to white. When finished, click **OK**. (The “please reverse” message will not appear if the reference plates are already set to white.)

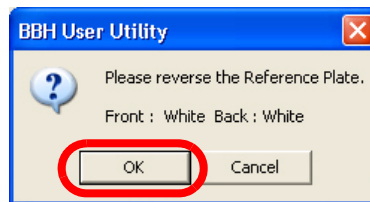

5. Place the special shading paper in the feeder tray or flatbed in the Landscape position, then click **OK**.

 **Note**

Use only shading paper that is in good condition. Do not use shading paper that is dirty or damaged because this will cause the image quality to deteriorate.

Use only the shading paper supplied with the scanner. Using other types of paper for shading adjustment will cause the image quality to deteriorate.

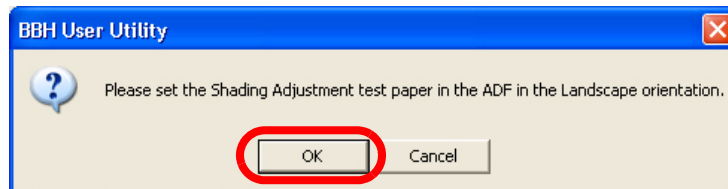

6. The scanner reads the shading paper and the shading adjustment sets the reference for the white shading plate. Wait until the "Now Adjusting" message box is cleared from the screen.

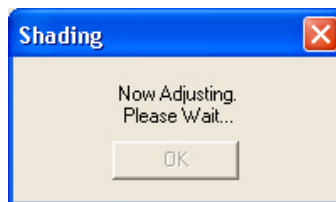

7. Turn over both the front and back reference plates to the black side. When finished, click **OK**.

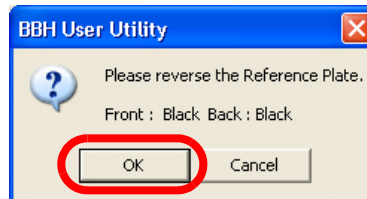

 **Note**

The shading paper is NOT used for the black reference shading.

The shading adjustment data with the black reference is created. Wait until the “Now Adjusting” message box is cleared from the screen.

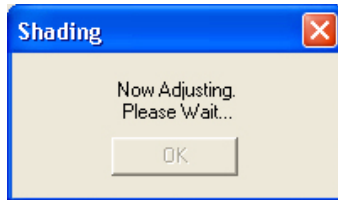

8. Click **OK** to complete shading adjustment.

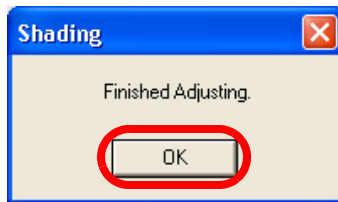

Restoring Shading to the Default

You can restore shading adjustment data to the factory default setting. Use this function if the image quality deteriorates or if it has not improved as a result of the shading adjustment process.

1. Click the **User Shading** button on the User Utility window.
2. Click the **Restore Default** option on the User Shading dialog box.

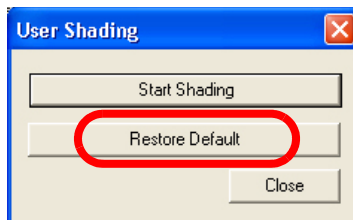

3. Click **OK** to confirm that you want to restore the factory setting.

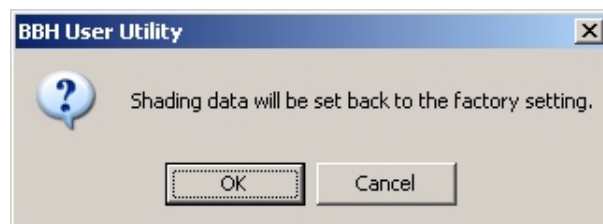

4. Click **OK** to complete the Restore Default function.

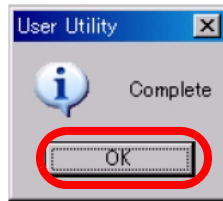

Scanner Counter

The User Utility scanner counters can be used to keep records of the number of documents scanned. The counters also provide a reminder for roller cleaning and parts replacement.

System

Displays the number of pages scanned in ADF mode after the last counter update.

Flatbed

Displays the number of pages scanned in flatbed mode after the last counter update.

The User Utility will display the correct number of pages scanned in flatbed mode just after the scanner operation. However, the number of pages is displayed in round numbers after the scanner's power is turned off and on. For example, the counter indication just after scanning 48 pages will be 48; the counter indication for the same number of pages just after turning the scanner off and on will be 40.

After Clean Roller

Displays the number of pages scanned after the rollers were last cleaned. When the After Clean Roller number is greater than the Warning number listed next to the counter, the rollers need to be cleaned. (The Warning number indicates how many pages can be scanned after roller cleaning before the rollers will need to be cleaned again.)

After Replace Roller

Displays the number of pages scanned after the rollers were last replaced. When the After Replace Roller number is greater than the Warning number listed next to the counter, the rollers need to be replaced. (The Warning number indicates how many pages can be scanned with a new set of rollers before the rollers will need to be replaced.)

Update All Counter

Click the **Update All Counter** button to update the counter displays to the latest numbers. Document scanning operations DO NOT automatically update the counter displays.

Clear Counter Buttons

There are two Clear Counter buttons, one to clear the After Clean Roller display and one to clear the After Replace Roller display.

- After you clean the rollers, click the **Clear Counter** button for After Clean Roller and reset the number to zero.
- After you replace the rollers, click the **Clear Counter** button for After Replace Roller and reset the counter to zero.

Help

Click the **Help** button to open the *Trüper Operator Manual* documentation in PDF file format. The manual contains information about scanner operations, cleaning and maintenance and information about the User Utility messages and error codes.

Select Scanner(X)

The Select Scanner button opens the Select Scanner dialog box. If more than one scanner is connected to the computer, you can use the Select Scanner dialog box to select a different scanner. The User Utility functions and settings will then apply to the selected scanner. To select a different scanner:

1. Click the **Select Scanner(X)** button.
2. Click the drop-down list and select a different scanner, then click **OK**. If you do not want to select a different scanner, click **Cancel**.

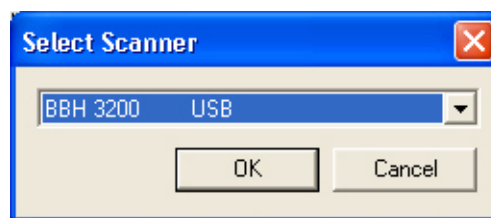

Save Info

The Save Info option allows you to save current scanner and computer system information to a log file.

1. Click the **Save info** button.
2. In the **Save in** drop-down list, browse to find a location to save the log file.
3. In the **File name** box, type a file name for the log file (the default file name is Scanner.log).
4. Click the **Save** button.

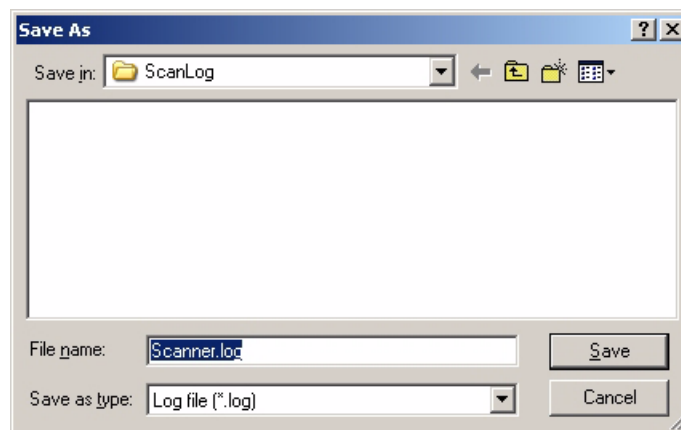

Close

Click the **Close** button to close the User Utility.

Check Version Information

To check the software version of the User Utility:

1. Open the User Utility and right click the title bar at the top of the display window.
2. Click the **About** option to view the version information.

Troubleshooting

User Utility Error Codes

If an issue occurs during scanning, click the  icon to open the Trüper User Utility. Check the Scanner Status message and look for Error Code information. The following table explains the error codes and messages and describes possible causes. The remedy column describes ways to resolve the problem.

Error Code	Status Message	Possible Cause	Remedy
—	Scanner has no error.		
U11	Jam occurred. Please open the door and remove the paper.	The document is jammed.	Open the ADF and exit doors and remove the jammed paper. See page 59 .
U12		Document sensors are dirty.	Clean the sensors. See page 89 .
U13			
U14			
U15			
U16			
U17			
U18	Document remains in the scanner. Please open the door and remove the paper.	Document remains in the scanner. Document sensors are dirty.	Open the ADF and exit doors and remove the paper. See page 59 . Clean the sensors. See page 89 .
U20	Skew error occurred.	A skew error has occurred.	Open the ADF and exit doors and remove the paper. See page 59 .
U23	Double feed occurred. Please open the door and remove the paper.	A double feed error has occurred.	Open the ADF and exit doors and remove the jammed paper. See page 59 .
		Rollers are dirty.	Clean the rollers. See page 79 .
U30	Scanner door is open. Please close the door.	The ADF door is open.	Close the ADF door. Do not slam the ADF door.
U32			
U34			
Fxx	System error occurred. Please consult with a service representative.	A system error has occurred.	Please contact a service representative.
—	***Warning*** The rollers need to be cleaned. Please clean the rollers. Please select Clear Counter button after cleaning the rollers.	Warning counter expired. Rollers need to be cleaned.	Clean the rollers. See page 79 . After cleaning the rollers, return to the User Utility and click the Clear Counter button for “After Clean Roller.” See page 106 .

Error Code	Status Message	Possible Cause	Remedy
—	***Warning*** The rollers need to be replaced. Please replace the rollers. Please select Clear Counter button after replacing the rollers.	Warning counter expired. Rollers need to be replaced.	Replace the rollers. See page 94 . After replacing the rollers, return to the User Utility and click the Clear Counter button for “After Replace Roller.” See page 106 .
—	*** Warning *** Insufficient front light error occurred. The lamp and/or scanning sensor need to be replaced.	It is time to replace the lamp and scanning sensor (front).	Replace the lamp and scanning sensor (front) by contacting your Authorized Service Provider.
—	*** Warning *** Insufficient back light error occurred. The lamp and/or scanning sensor need to be replaced.	It is time to replace the lamp and scanning sensor (back).	Replace the lamp and scanning sensor (back) by contacting your Authorized Service Provider.
—	*** Warning *** The front reference plate may need to be cleaned. Please clean the front reference plate.	The front reference plate is dirty.	Clean the front reference plate. See page 87 .
—	*** Warning *** The back reference plate may need to be cleaned. Please clean the back reference plate.	The back reference plate is dirty.	Clean the back reference plate. See page 87 .
—	Scanner is not connected.	The scanner is not connected.	Connect the scanner to the computer, turn on the scanner and restart the computer.
		The scanner is not turned on.	Turn on the power to the scanner and then restart the computer.
		The computer was turned on before the scanner was ready.	Restart the computer.

Troubleshooting Scanner Operations

If a problem still exists after you have checked the User Utility Status Messages and Error Codes as described in the previous section, check the items in the following table. If the scanner still malfunctions after you have checked these troubleshooting options, turn the scanner off, unplug the power cord and call for service.

Symptom	Possible Cause	Remedy	
The LED does not light when the power switch is turned on.	Power cord is not plugged in.	Insert the power cord firmly into the power outlet and into the scanner power input.	
	Problem with power supply.	Disconnect the scanner from the power outlet and call for service.	
The computer does not recognize the scanner.	Scanner is not connected to the computer properly.	Connect the interface cable properly. See page 28 (USB) or page 114 (SCSI).	
	Scanner has not been properly configured using the Windows "Found New hardware" procedure.	Uninstall the scanner from the computer. Reinstall the scanner in order to recognize the scanner hardware. See page 29 .	
	USB connection	The USB interface of the computer is not installed properly.	Check the computer to determine if the USB interface is installed properly. Check the USB properties using the Windows Device Manager.
		The scanner is connected to a USB hub.	Do not connect the scanner to a USB hub.
		The USB cable does not have a High Speed logo.	Use the cable provided with the scanner.
	SCSI connection	The computer cannot recognize the SCSI board.	Check the computer to determine if the SCSI board is installed properly. Check the SCSI properties using the Windows Device Manager.
		The same SCSI ID number is used for the scanner and another device.	Use different SCSI ID numbers for each device. See page 115 .
		The scanner was turned on after the computer was turned on.	Turn the computer off. Turn the scanner on and then turn the computer on again.

Symptom	Possible Cause	Remedy
Scanning speed is too slow using the USB connection.	The scanner is connected with a USB 1.1 interface.	Verify the type of USB interface. Connect with a USB 2.0 interface.
The ADF door does not open when the ADF door release is pushed.	The ADF door is not closed properly.	(1) Push the ADF door release button and lift up the ADF door. See page 59 . (2) Close the ADF door securely until it is locked. Do not slam the ADF door.
(ADF) The document has been loaded on the feeder tray, but the scanner does not start scanning.	The document is not loaded properly.	Load the document properly. See page 55 .
	The sensor cannot detect the document because the edge of the document is curled.	Flatten the document and load it again. See page 52 .
(ADF) Double feeding or skewing problems occur frequently, or the scanner stops loading while scanning.	The rollers are dirty.	Clean all the rollers. See page 79 .
	The rollers have reached their life expectancy.	Replace the paper feed roller module and the retard roller module. See page 94 .
	The document is curled or folded.	Flatten the document, reduce the number of sheets to be scanned and load the document again. See page 52 and page 55 .
	An irregular type of document needs to be scanned.	Use the flatbed scanner. See page 70 .
	The document has a length of less than 2.75 in. (70 mm).	Use the flatbed scanner. See page 70 .
(ADF) Scanned image is skewed.	The document guides are not adjusted to the size of the document to be scanned. The document to be scanned is positioned at a slant on the feeder tray.	Adjust the document guides properly to the size of the document to be scanned. Straighten the document on the feeder tray. See page 55 .
	The right and left sides of the document to be scanned are not the same height because of curls or folds.	Remove the curls or folds, reduce the number of sheets to be scanned and load the document again. See page 52 .
(ADF) The scanned document is blank.	The document to be scanned was loaded facing down (upside down).	Load the document properly. See page 55 .

Symptom	Possible Cause	Remedy
Vertical lines appear on the scanned document.	The ADF glass areas or the flatbed glass is dirty.	Clean the ADF glass areas and the flatbed glass. See page 87 .
	The reference plates or the flatbed sheet is dirty.	Clean the reference plates and the flatbed sheet. See page 87 .
The scanning density is uneven.	The ADF glass areas, reference plates, flatbed glass, or flatbed sheet is dirty.	Clean the ADF glass areas, reference plates, flatbed glass and flatbed sheet. See page 87 and page 92 .
	The distribution of the quantity of light in the scan varies.	Perform the shading adjustment. See page 141 .
The color of the scanned document is very different from the original document.	The settings of the computer display or the monitor are not correct.	Adjust the computer display and monitor settings.
Dark spots or noise appear on the scanned documents.	The ADF glass areas, reference plates, flatbed glass, or flatbed sheet are dirty.	Clean the ADF glass areas, reference plates, flatbed glass and flatbed sheet. See page 87 and page 92 .
Scanned image has moire fringes or patterns, such as stripes or wavy pattern noise.	This is caused by the original printing pattern on the document and the selected scanning resolution.	Use the moire reduction function or change the scanning resolution, then scan the document again.
Image crop failures with VRS scanning.	There are unwanted objects such as paper or dust on the reference plates.	Examine and clean the reference plates. See page 87 .

SCSI Interface Connection

The Trüper scanner may be connected to a computer system using the SCSI interface instead of the USB interface. To use the scanner with a SCSI connection, the computer system to which you connect the unit must have a SCSI adapter board. You will also need to obtain and connect a SCSI interface cable.

Item	Compatible with Trüper
Interface	SCSI III
SCSI Board	Recommended: Adaptec SCSI 2940U, Kofax Adrenaline 450, or Kofax Adrenaline 650i

➔ Note

Connecting the scanner with another SCSI device in a daisy chain is **NOT RECOMMENDED**.

We recommend that you use a SCSI cable that is shorter in length than that recommended by the manufacturer of the SCSI board.

Connecting the Scanner

- 1** Before you connect the SCSI interface cable, press the scanner power switch to the OFF position and turn off the power for the computer.
- 2** Connect one end of the SCSI cable to an available SCSI port on the computer and connect the other end to the SCSI connector on the scanner.

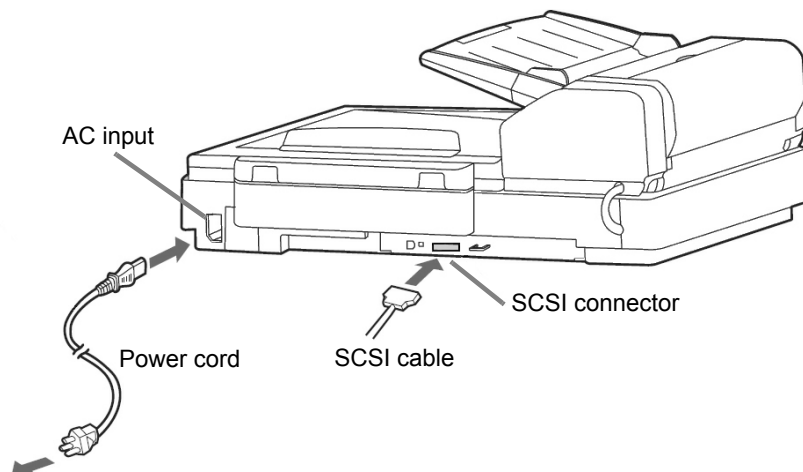

Do not connect a USB and a SCSI cable to the scanner at the same time.

- 3** Press the scanner power switch to the ON position.
- The LED will at first display a flashing orange light.
 - The scanner is ready when the LED displays a steady green light.

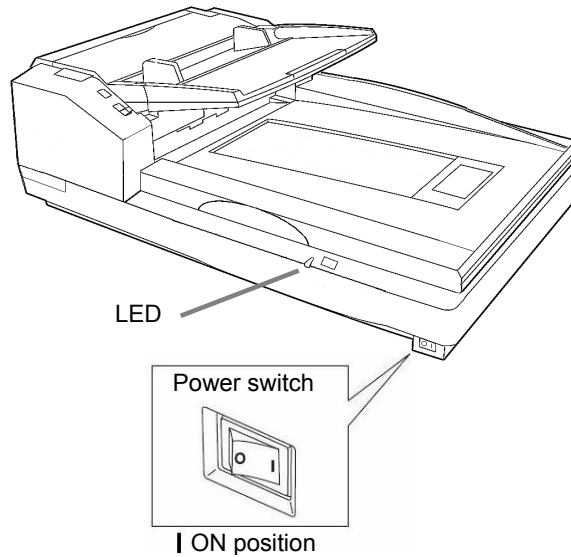

- 4** Turn on the power for the computer.

Information on SCSI ID settings is presented in the next section. If a problem occurs with the SCSI connection, refer to [“Troubleshooting Scanner Operations” on page 111](#).

SCSI ID Setting

Use the following table to find the correct DIP switch setting for a SCSI ID number for the scanner.

ID Number	DIP Switch			Remarks
	#2	#1	#0	
0	OFF	OFF	OFF	Do Not Use
1	OFF	OFF	ON	
2	OFF	ON	OFF	
3	OFF	ON	ON	
4	ON	OFF	OFF	
5	ON	OFF	ON	
6	ON	ON	OFF	Default setting
7	ON	ON	ON	

Use the DIP switch located on the back side of the scanner to set the SCSI ID number. The diagram shows the DIP switch in the default setting.

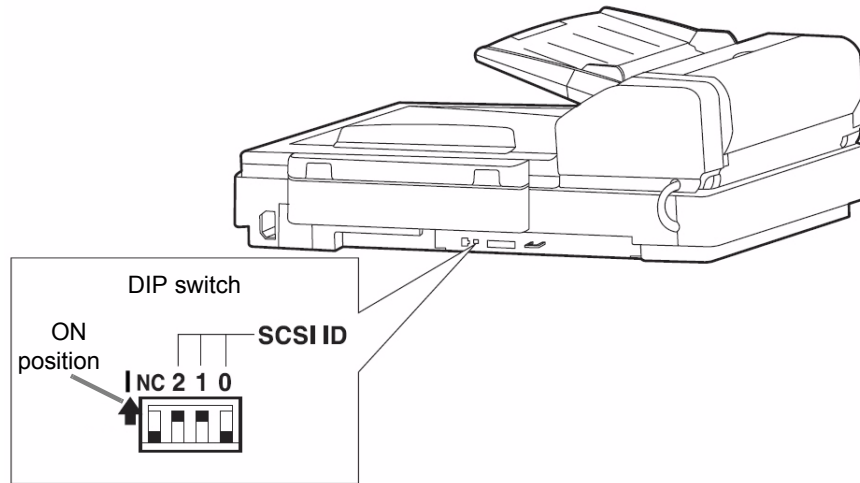

Note

NC = Not Connected

Repacking Instructions

If you need to transport or ship the scanner, please follow these guidelines and instructions:

- Use the original scanner carton and packing materials. You will also need shipping tape and scissors.
- Improper repacking of the scanner may cause damage during handling and shipment.
- The scanner should always be handled in the horizontal position.

- 1** Press the power switch to the OFF position. Disconnect the scanner from the electrical outlet and disconnect the interface cable.

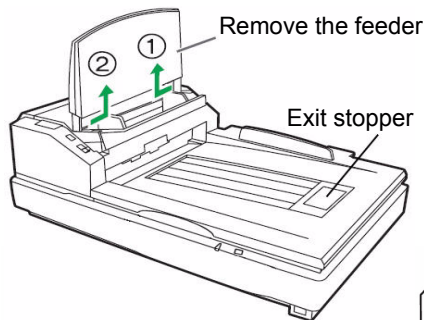

- 2** Remove the feeder tray at points (1) and (2). (See [page 27](#).) Wrap the tray with protective sheets of plastic. Seal the plastic with tape. Fold down the exit stopper.

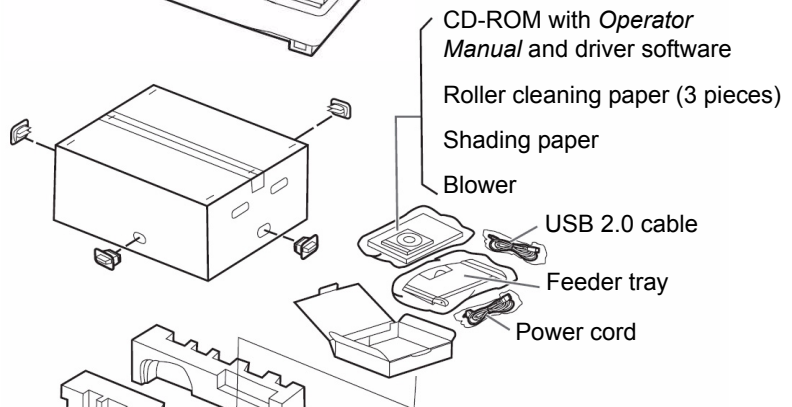

- 3** Pack the scanner in the original carton and packing materials. Note the packing arrangement in the diagram.

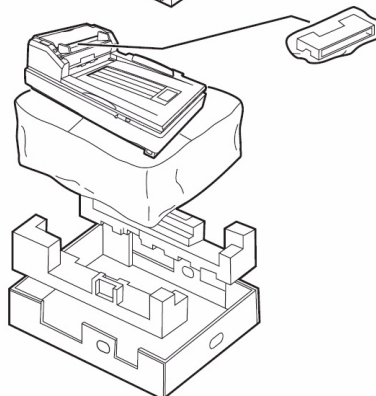

Glossary

Automatic Document Feed (ADF) mode. The scanner mode in which the documents are automatically fed, rather than manually fed, into the document feeder.

Crop (Auto Crop). This software option automatically crops every page to its original size by looking for page or document borders.

Deskew. The process of electronically straightening an image after it has been scanned. This can be done through software or through firmware on the scanner.

Document feed guides. The adjustable rails or bars on the automatic or manual feeder between which the operator feeds the document.

Double Feed. Occurs when more than one document is fed through the feeder at once.

Duplex scanner. A scanner capable of scanning both sides of a document in a single pass through the scanner.

Error message. A message displayed in the User Utility dialog display screen, or an indicator light on the LED status indicator. Error messages or indicators appear whenever the scanner determines that a problem exists.

Exit door. The assembly that performs scanning in ADF (Automatic Document Feeder) mode. Opening the exit door allows access to the ADF glass areas, background reference plates and rollers.

Exit tray. The output tray of the scanner. As the documents are scanned, they exit the scanner and are stacked, face down, in this tray.

Feed Roller Assembly. The roller assembly of the feeder that sits on top of the stack of documents on the feeder tray. This is the roller assembly that feeds the documents into the scanner.

Feeder. Feeds documents automatically or manually on command from the workstation (host computer). These documents are stacked in the feeder before the scanner requests them.

Flatbed sheet. Adjustable component used in conjunction with the reference plates to change the background color of the scanned document.

Glass (ADF glass or flatbed glass). The piece of glass through which the scanner camera “sees” the document. Light from the lamps passes through this glass to illuminate the document.

Imprinter. Option that allows for front page pre-scan imprinting of a string of alphanumeric characters on documents that are fed into the scanner transport.

Interface cable. The cable connecting the scanner to the computer.

Manual mode. The scanner mode in which documents are manually fed by the operator, rather than automatically fed into the feeder.

Paper jam. The scanner considers that a paper jam has occurred if the document takes longer than normal to exit from the scanner.

Paper path. The curved path taken by a document as it passes through the scanner.

Paper transport. The mechanical system for moving a document through the scanner.

Power cord. The cord that connects the scanner to AC power.

Power input. The connector at the rear of the scanner into which the power cord is inserted. The other end of the power cord is plugged into the wall outlet or other source of AC power.

Reference plates or background reference plates. Adjustable components used to change the background color of the scanned document.

Resolution. A measurement of the ability of a scanner to reproduce small objects. The higher the resolution, the smaller the object the scanner can reproduce. Resolution is measured in dots per inch (dpi).

RGB. Three components of color: Red, Green, Blue.

Rollers. Rollers, spaced along the paper path, move the documents to be scanned through the mechanical section of the scanner.

SCSI (Small Computer System Interface). A data transmission system that operates between the scanner and the host computer system.

Separation roller. This roller holds back all but the top document in the stack of documents. This roller allows the paper feed roller to feed a single document at a time into the scanner.

Simplex scanner. A scanner designed to scan a single side of a document as it passes through the scanner.

Skew. The result of feeding a document at an angle. It appears crooked or misaligned on the display and also looks this way when printed. To minimize skew, guide the document against the left document feed guide.

Single Color Dropout. An option on the scanner that allows the user to drop out red, green, or blue color from a bitonal image.

Transport system. See *Paper transport*.

USB (Universal Serial Bus). A data transmission system that operates between the scanner and the host computer system.

VRS (VirtualReScan). VRS is an electronic check-point for scanned images. As images pass through the scanner, VRS performs a multi-point inspection of each document. VRS automatically checks and adjusts for alignment (skew), brightness, contrast and image clarity.

Appendix 1—Front Page, Pre-Scan Imprinter Installation

The optional pre-scan imprinter unit and replacement ink cartridges are available from the Böwe Bell + Howell Scanning Essentials online store at <http://webstore.bbhscanners.com> or from the reseller where you purchased the Trüper scanner. See also the “Consumable Parts List” on page 13.

Safety Precautions



Caution

Keep the ink cartridge out of the reach of children.



Do not disassemble the imprinter unit and ink cartridge.

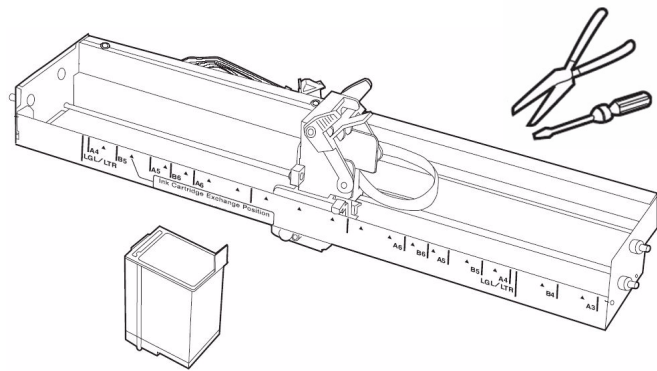

When the ink cartridge is at the end of its useful life, do not dispose of it in fire.

Component Identification

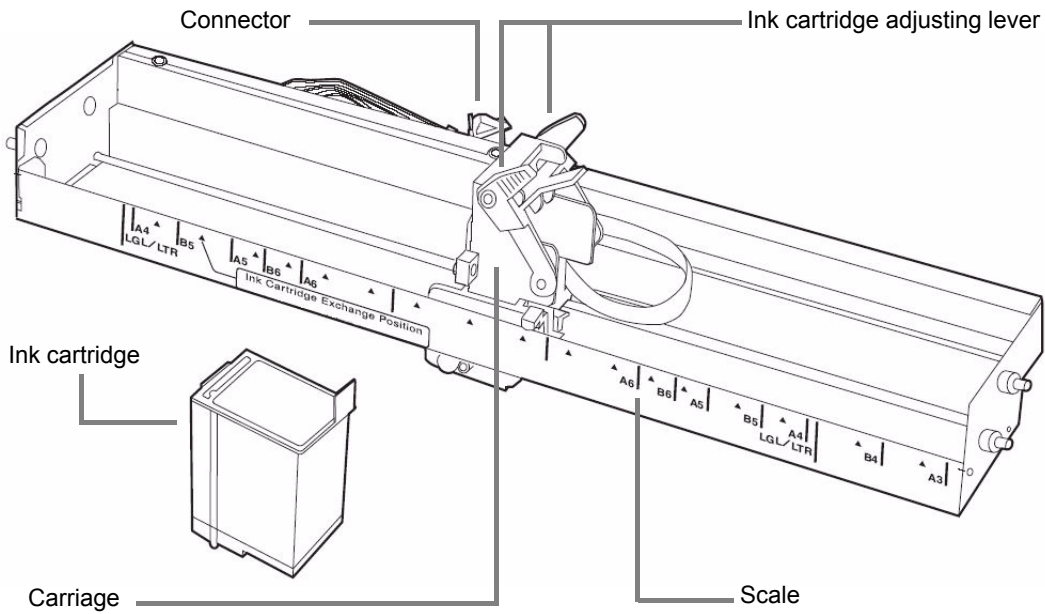

Installing the Imprinter Unit

- 1 Turn the scanner power switch to the OFF position.

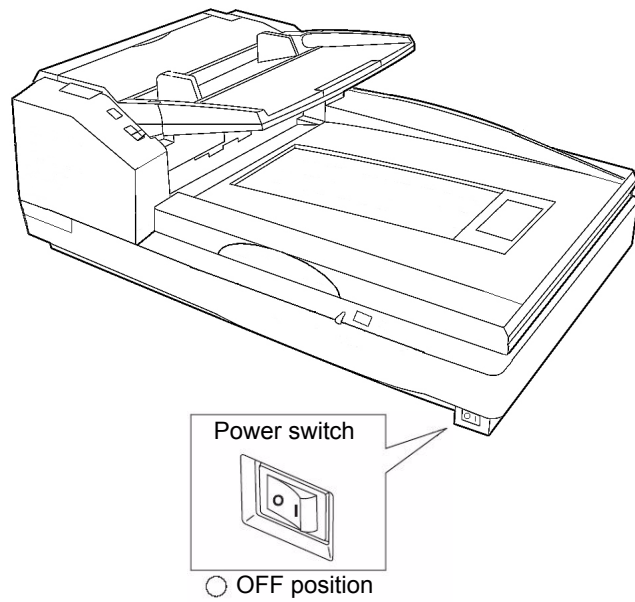

2 Open the imprinter door in the direction of the arrow.

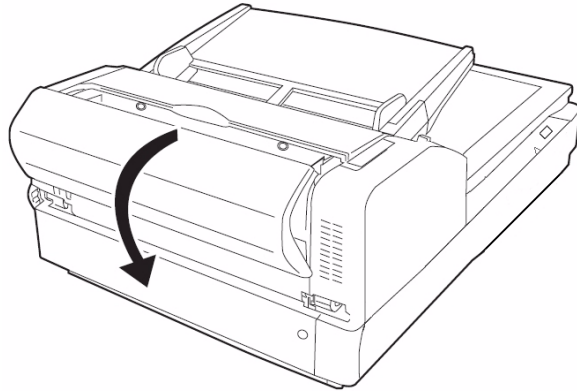

3 Connect the imprinter cable to the connector on the scanner.

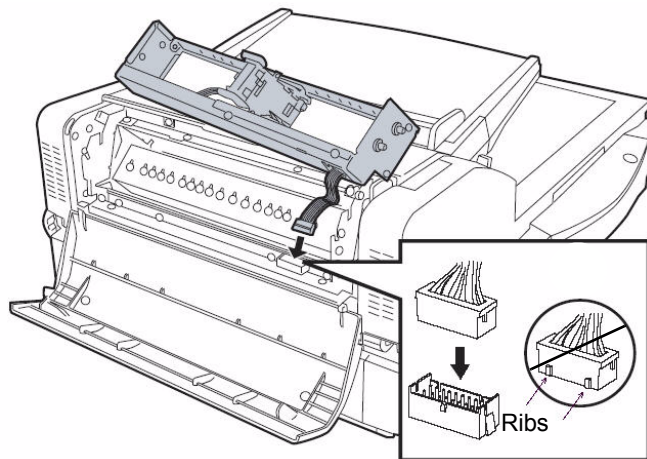

Note

Before you insert the connector, be sure to match the rib on the imprinter cable connector with the slot on the scanner connector.

- 4** Insert the upper pins on the imprinter unit into the guides located on the bracket. Match the channels in the pins with the guides.

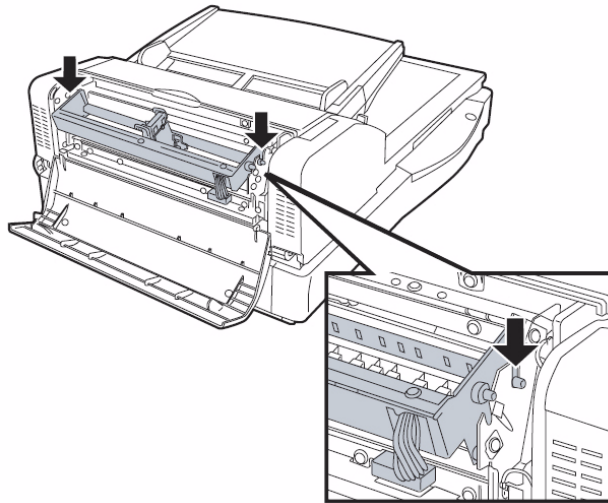

- 5** Insert the lower pins into the guides located on the bracket. Match the channels in the pins with the guides. Gently insert the pins until they are locked in place by the springs.

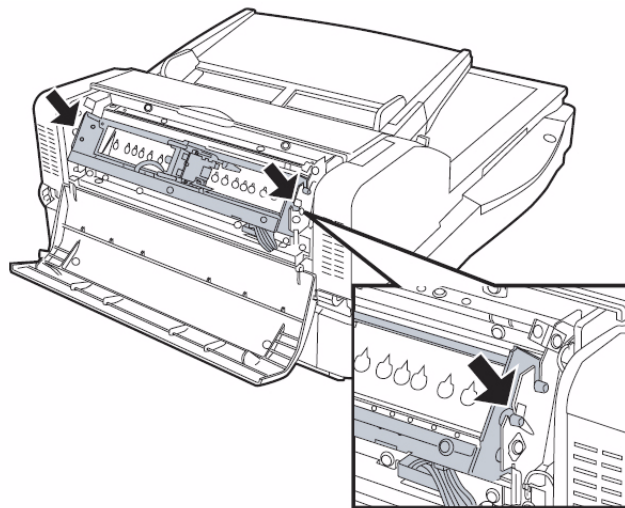

- 6** Close the imprinter door in the direction of the arrow.
- When you close the imprinter door, close it securely until the door is locked. Do not slam the imprinter door.

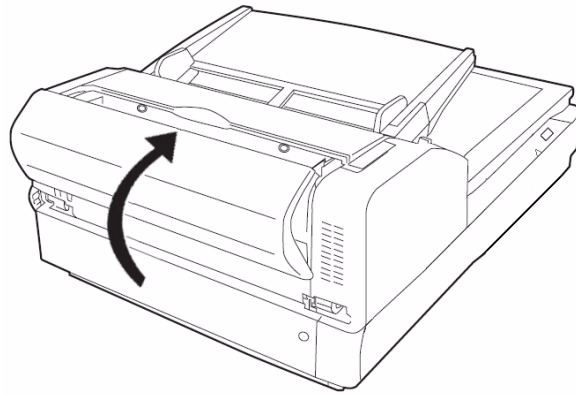

Ink Cartridge Installation and Printing Position

Safety Precautions

Before installing the ink cartridge, please note the following precautions and instructions:

- Do not touch the print head with your hands or with a dirty object.
- Do not subject the ink cartridge to shock.
- If the date marked on the ink cartridge box has expired, the print quality may be affected.
- If the ink cartridge is used six months after unpacking the unit, the print quality may be affected.
- Be sure that the storage temperature is between 32°F and 104°F (0°C and 40°C).
- Store the ink cartridge away from direct sunlight.
- Do not clean the ink cartridge with alcohol.



Warning

- Do not disassemble the ink cartridge.
- Do not let the ink come into contact with your skin.
- If the ink comes into contact with eyes, rinse the area completely with fresh water. If irritation or pain remains after rinsing, consult a doctor immediately.
- Keep the ink cartridge out of children's reach.
- Do not dispose of the ink cartridge in fire.

Installing the Ink Cartridge

- 1** Remove the protective tape from the ink cartridge.

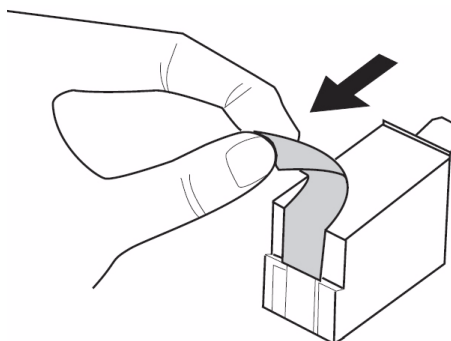

- 2** Move the carriage on the imprinter unit to the position for ink cartridge exchange, as shown in the diagram.

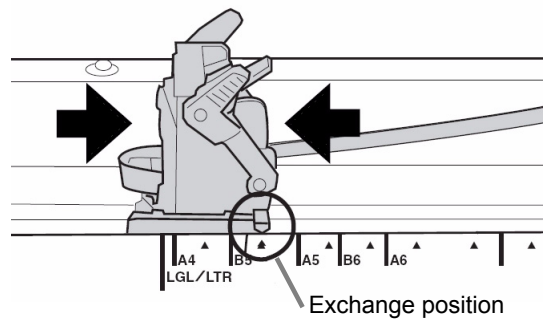

- 3** Insert the ink cartridge into the carriage, as shown in the diagram.

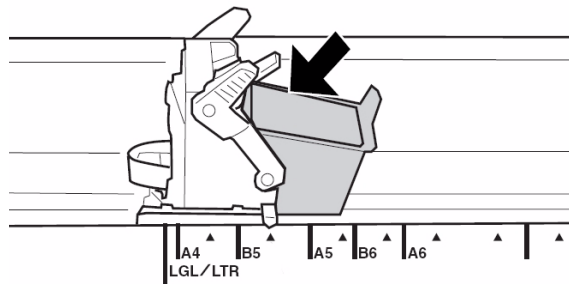

- 4** Lock the cartridge adjusting lever, as shown in the diagram.

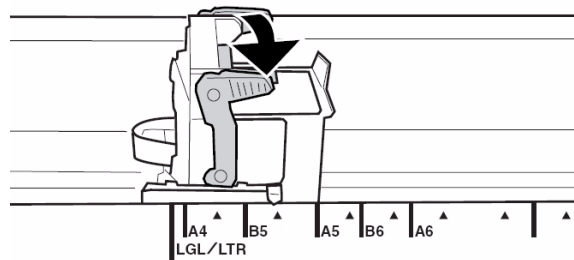

Adjusting the Printing Position

To add an imprint to the page that will appear on the scanned image, adjust the position of the printer carriage according to the size of the sheets that you want to scan. Move the printer carriage to align the tab on carriage with one of the ▲ marks that appears in the scale on the side of the imprinter unit. For the imprint to appear on the right side of the page, move the carriage to the right side of the scale. For the imprint to appear on the left side of the page, move the carriage to the left side of the scale.

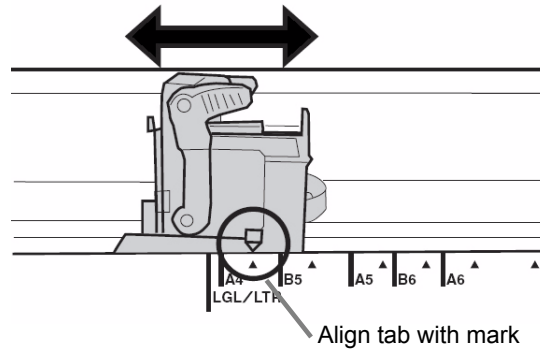

The tab on the printer carriage must be aligned with one of the marks on the scale. If the carriage is not properly aligned, the unit will not print.

Printing Position Chart

This chart shows the position of the imprint according to the sheet size you select when you adjust the printer position.

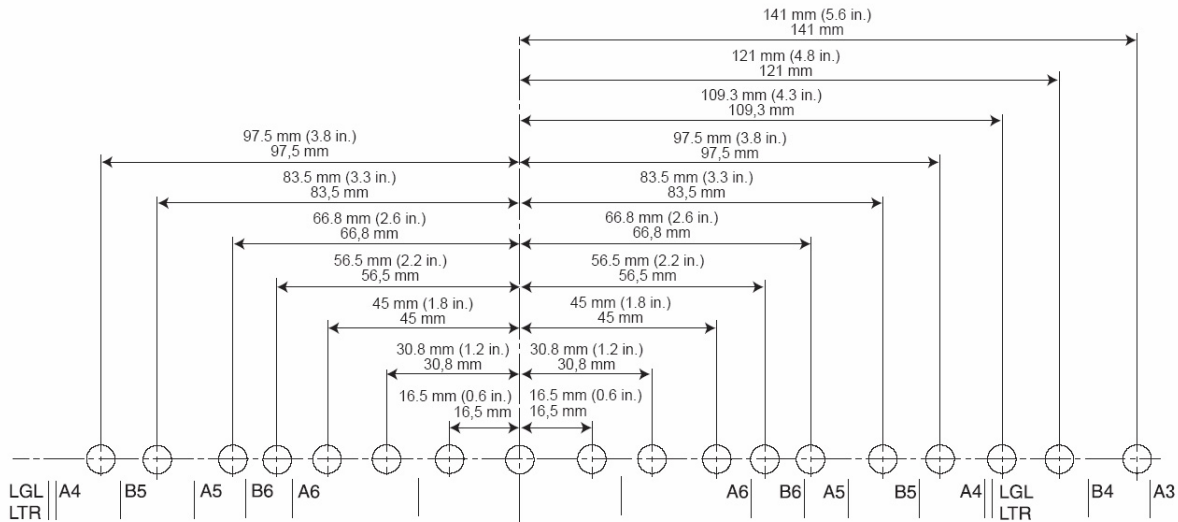

To set other printing parameters, see the instructions for your scanning or document management software application.

 **Note**

With certain types of paper, the ink from the imprinter may stain the inside of the scanner. For example, ink may stain the scanner rollers. If this occurs, clean the areas affected by using the roller cleaning paper. (See [“Roller Cleaning Paper” on page 80.](#))

Cleaning the Ink Cartridge

If the head of the ink cartridge is dirty or if the ink cartridge has not been used for a long period of time, it may not print properly.

Cleaning the Print Head with the User Utility

Click the  icon to open the Trüper User Utility, then click the **Imprinter Cleaning** button. The unit will perform an automatic cleaning function to improve the print quality.

Cleaning the Print Head Manually

Remove the ink cartridge as described in [“Removing the Ink Cartridge” on page 130](#). Use a moistened tissue paper to gently wipe and clean the print head.



Do not use the roller cleaning paper to clean the print head. Do not use any material that contains alcohol when cleaning the print head.

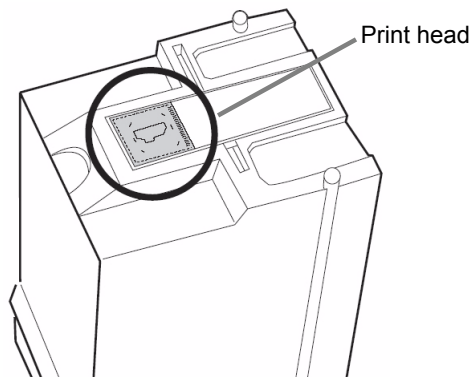

Removing the Ink Cartridge

- 1 Move the carriage on the imprinter unit to the position for ink cartridge exchange, as shown in the diagram.

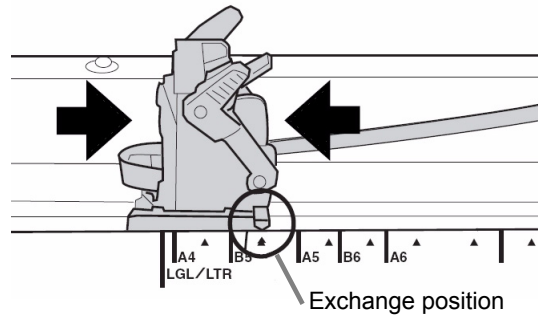

- 2 Pinch the cartridge adjusting lever (1) and lift the cartridge (2). You can now remove the ink cartridge.

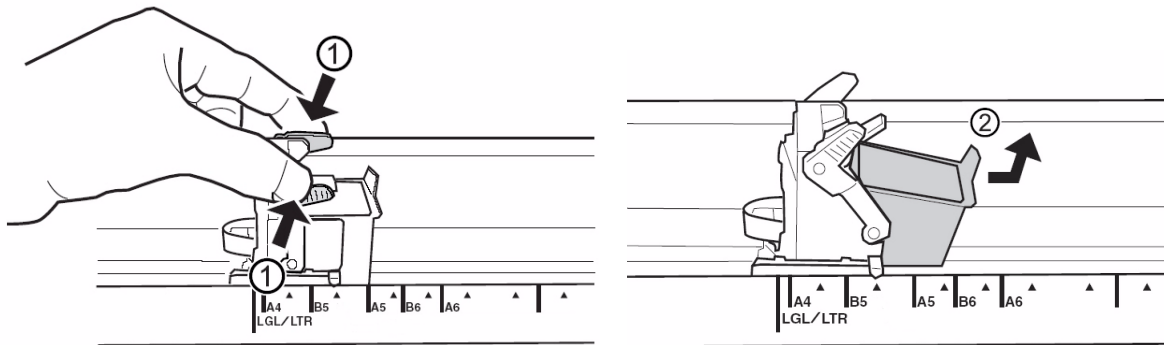

Ink Cartridge Specifications

Ink Cartridge Life	Approximately 4,000,000 characters (standard font) Approximately 2,000,000 characters (bold font)
Number of Characters	VC Demo 62 characters, QuickScan 72 characters
	The numbers of characters will vary according to the application.
Nozzles	12
Unusable documents	Plastic film or coated paper should not be used with the imprinter
Storage environment	Temperature: 32°F to 104°F (0°C to 40°C), Humidity: 10% to 80% RH
Operating environment	Temperature: 59°F to 86°F (15°C to 30°C), Humidity: 30% to 80% RH

Additional ink cartridges are available from the Böwe Bell + Howell Scanning Essentials online store at <http://webstore.bbhscanners.com> or from the reseller where you purchased the Trüper scanner. See also the [“Consumable Parts List” on page 13](#).

Imprinter (Endorser)

This function prints on the documents to be scanned. *Pre Imprinter* prints on the front sides of document sheets before they are scanned. The printed results are also reflected on the scanned images.

Note

A Starting Number Automatic Increment function is provided. When used, the starting number is incremented to the number at the start of scanning + (number of pages scanned x step number) upon completion of scanning.

1. In the Imprinter Setting dialog box, select the **Enable** check box.

The **Imprinter String** field now appears.

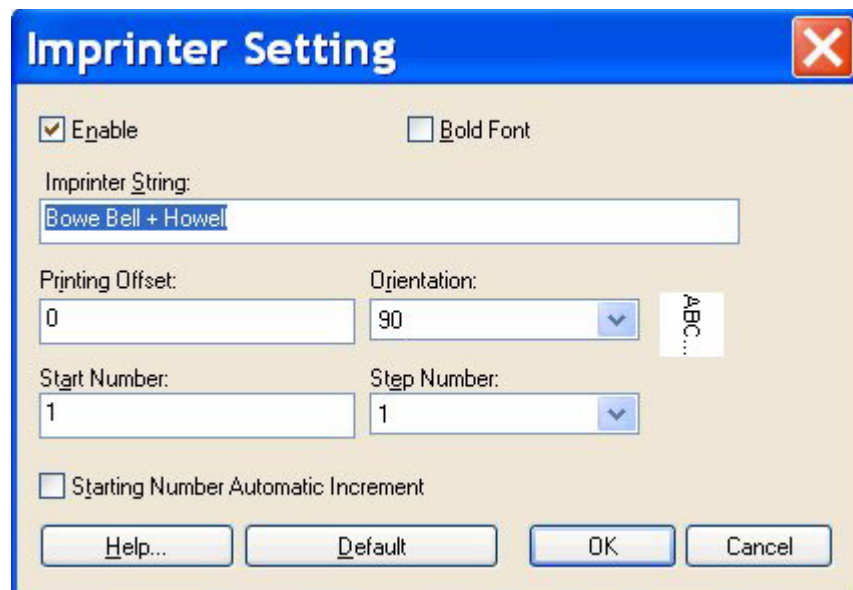
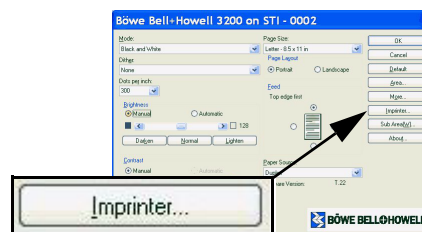

2. To print in bold type, select the **Bold Font** check box.

3. In the **Imprinter String** field, type in the character string to be printed.

The alphanumerics and symbols in the following table can be printed. In addition, other information such as the date and time can be specified. Up to 72 characters can be printed.

SP	!	'	#	\$	%	&	'	()	=		,	-	/	0	1	2	3	4	5	6	7	8	
9	:		<	=	>	?	@	A	B	C	D	E	F	G	H	I	J	K	L	M	N	O	P	Q
R	S	T	U	V	W	X	Y	Z	[\]	^		a	b	c	d	e	f	g	h	i	j	k
l	m	n	o	p	q	r	s	t	u	v	w	x	y	z	{		}							

4. In the **Start Number** field, type in the default value of the counter specified by the imprinter string.
5. In the **Step Number** field, type in the step number of the counter specified by the imprinter string.
6. Type in the printing offset in the **Printing Offset** field.

A 10 mm offset is always added to this value.

Unit: 2.38 mm per increment (printing orientation: 900, 270°)

- 1: 12.38mm
- 2: 14.76 mm

Unit: 3.44 mm per increment (printing orientation: 00, 180°)

- 1: 13.44mm
- 2: 16.88 mm

7. Select the printing orientation in the **Orientation** drop-down list.

Appendix 2—Multicolor Dropout (MCD) and Single Color Dropout

This appendix describes the basic functionality of how to use the Bowe Bell + Howell Trüper MCD (Multicolor Dropout). MCD allows the operator to select any combination of up to six different user settable, color dropout schemes

Note

MCD is only functional in the Black and White mode. MCD does not dropout colors when in Color mode.

Term	Description
UI	Windows User Interface
RGB	Red, Green, Blue
Dropout	Color to be removed from a color document when scanning in Black and White mode
MCD (Multicolor Dropout)	A combination of colors to be removed from a color document, when scanning in Black and White mode

Single Color Dropout

Single Color Dropout is used in document scans to delete colored text or lines printed on documents in the specified colors of red, blue or green. It is used mostly in OCR (Optical Character Reading) to dropout the form lines.

Note

The Single Color Dropout function can be set independently for the front and back of a document.

The function can be used only with binary images in the Black and White or Binary modes.

Depending on the scanning conditions and colors, it may not be possible to delete the specified colors completely.

1. Navigate to your scanning application and select **Advanced Settings**.
2. Click the **More** button in the Settings dialog box.

3. Select **Red**, **Green** or **Blue** from the **Single Color** drop-down list in **Advanced Settings** dialog box.

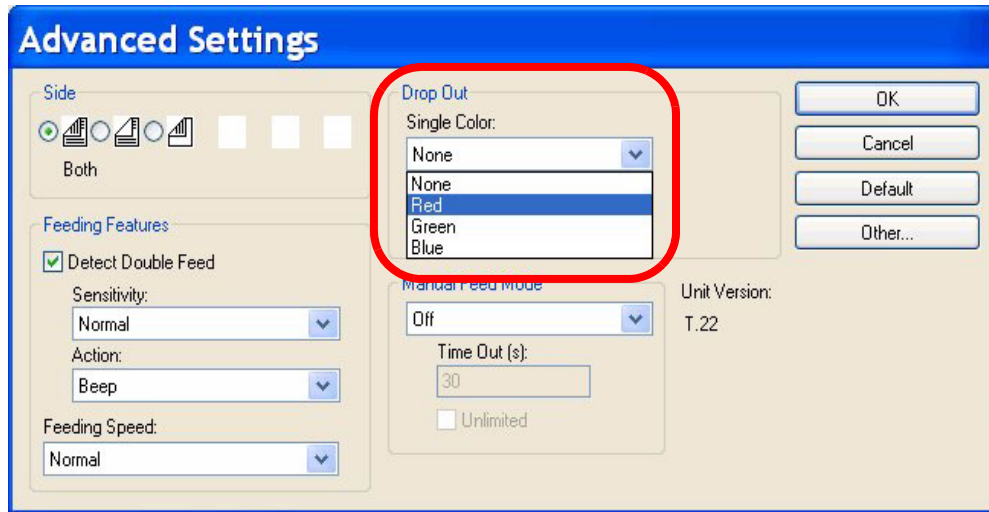

4. Click the **OK** button.

Multicolor Dropout (MCD)

The Multicolor Dropout function can be used to specify and remove up to 6 colors.

1. Navigate to your scanning application and select **Settings**.
2. Click the **More** button in the Settings dialog box.
3. Click the **Dropout** button.

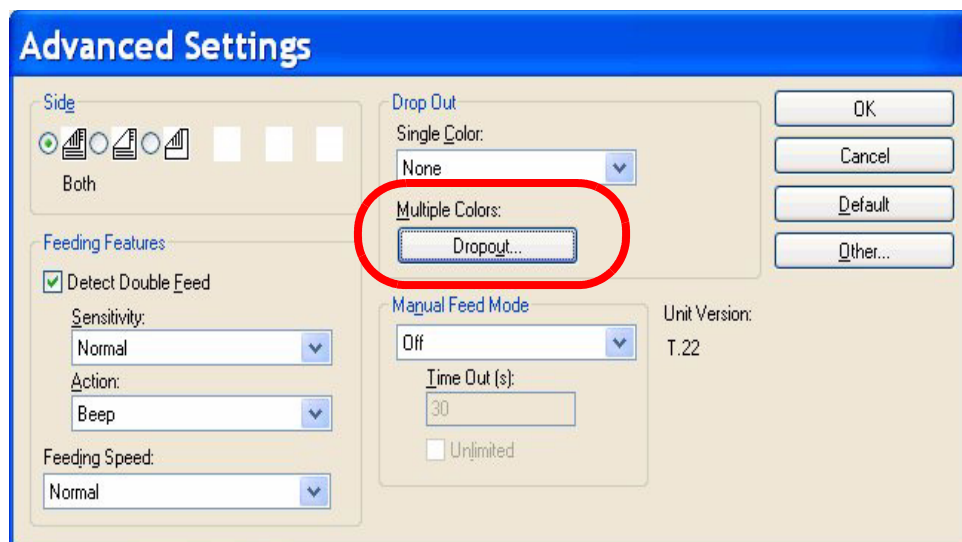

Selecting Multicolor Dropout

1. Click the **Selection 1** radio button.
2. Select the **Enable** check box, and then click the **Choose** button.

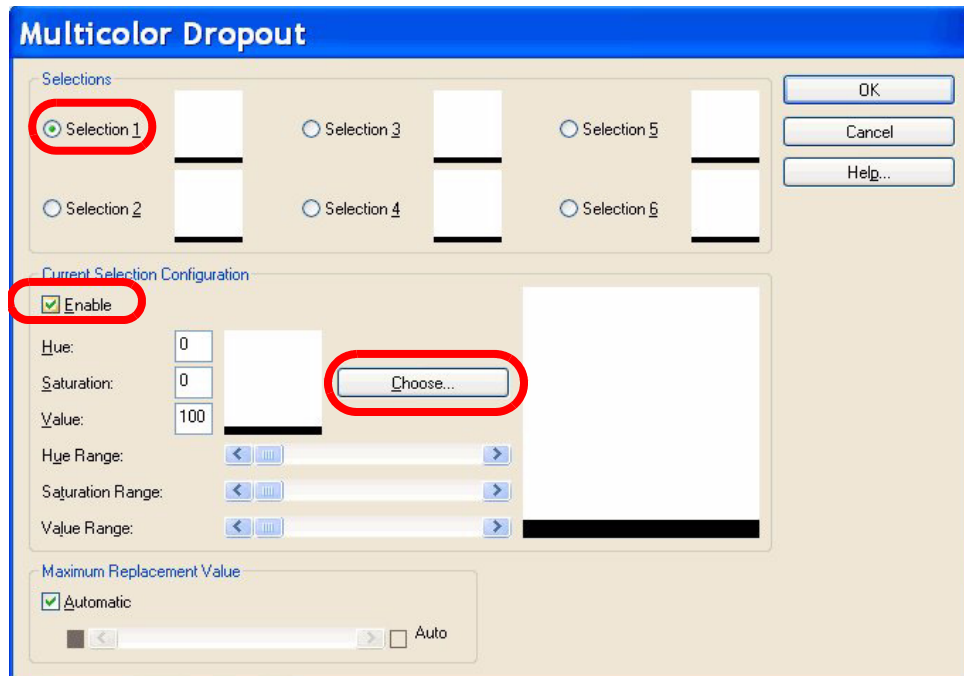

3. Enter the RGB number or HiZoom values and then click **OK**.

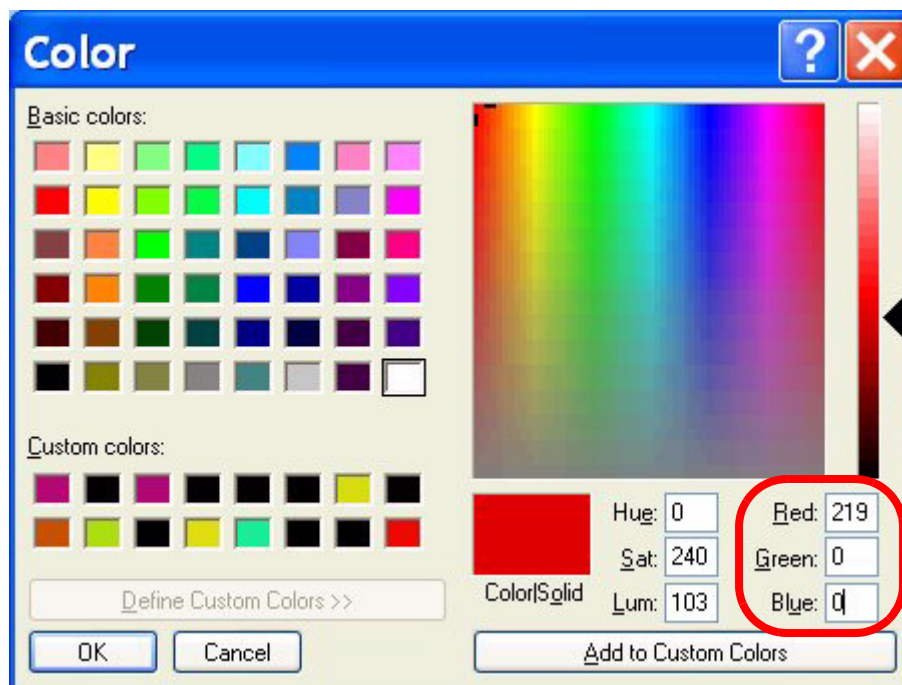

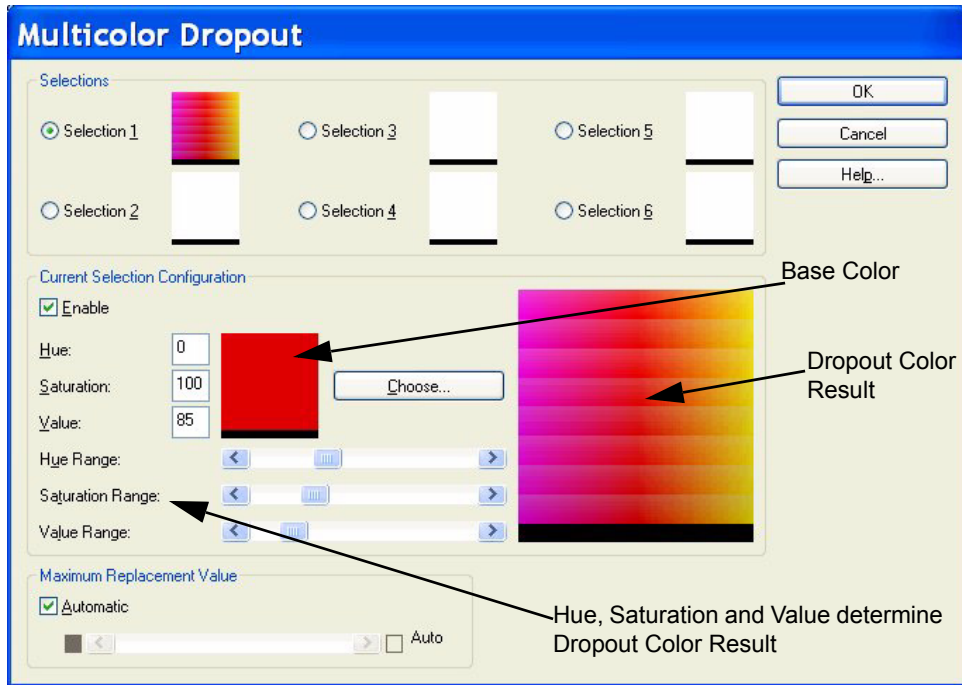

➔ Note

The default values for Hue, Saturation and Value are typically accurate. However, if the dropout color requires adjusting, the Hue, Saturation and Value numbers can be modified manually.

4. If desired, do one of the following:

- Adjust the numbers in **Hue**, **Saturation** and **Value** text boxes.

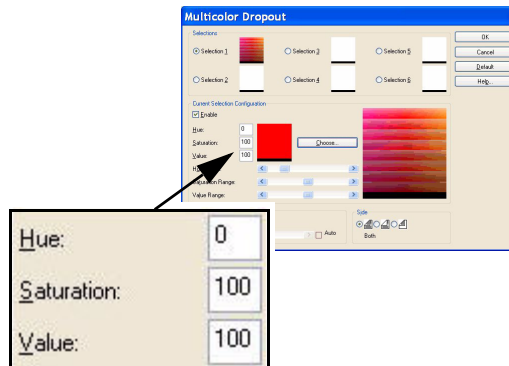

➔ Note

Hue determines the color and can contain values of 0-3601. *Saturation* defines the intensity of the color and can contain values of 0-1000. *Value* controls the brightness of the color and can range from 0-1000.

- Adjust the **Hue Range**, **Saturation Range**, and **Value Range** bars.

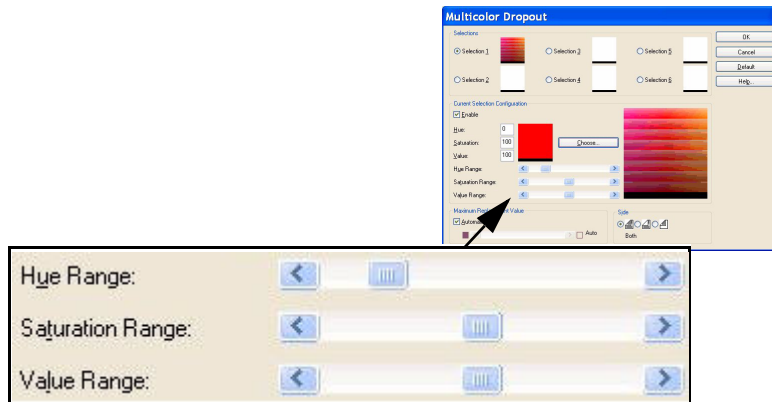

➔ Note

Hue Range determines how many colors to dropout, while the *Saturation Range* controls the amount of intensity to dropout and the *Value Range* is the level of brightness to dropout.

5. To add additional dropout colors, click the next **Selection** radio button and repeat steps 2 through 4. There can be up to 6 dropout colors.
6. In the Maximum Replacement Value section, do one of the following:
 - Select the **Automatic** check box and adjust the bar accordingly.
 - Select the **Auto** check box to completely dropout the color.

To disable a dropout color:

- Select the radio button for the color you want to disable and then clear the **Enable** check box.

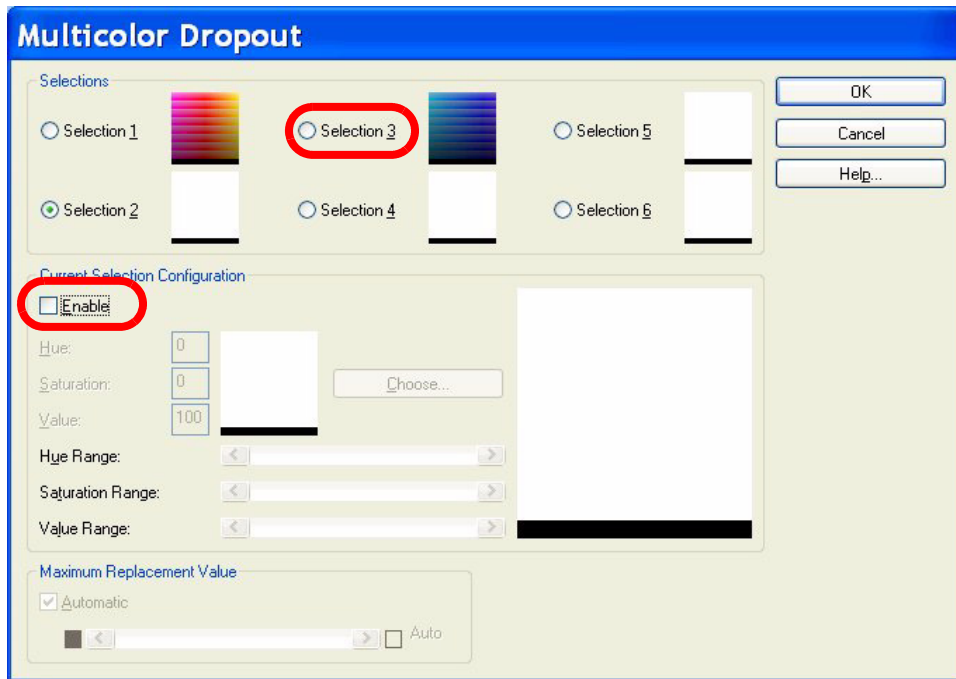

Note

Any and all of the selections can be active at the same time.

When setting ranges to the Hue, Saturation, and Value Ranges, the user can always reset the slide bars to the starting recommended default ranges.

How to Determine RGB Value

To determine your color RGB value, do the following:

1. Select **24-bit Color** from the **Mode** drop-down list.

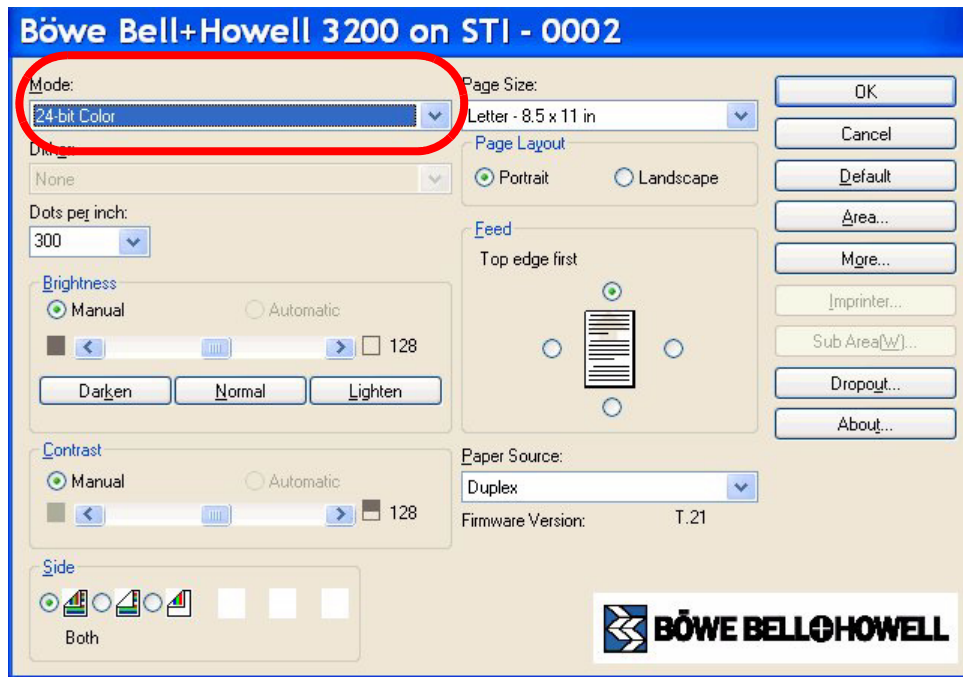

2. Set the document size: Page Size, Page Layout, Feed, Dots per inch (300 is a good standard) and Paper Source.
3. Using your scanning application, scan the document that has the colors you want to drop out.
4. Using the utility HiZoom, point to which color on your scanned document you want to dropout.

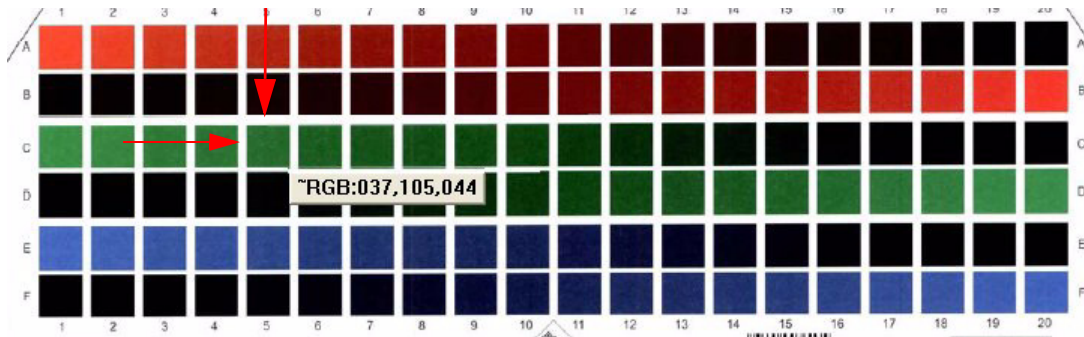

HiZoom is pointing to the color on grid C,5.

Note

The utility HiZoom software can be installed from the Installation Resource CD.

Appendix 3—Shading Adjustment

About Shading Adjustment

What Is the Purpose of Shading Adjustment?

The process whereby variations in the distribution of the scanning lamp's quantity of light are transformed into a fixed output within the scanning range is known as shading adjustment. Shading adjustment can be performed using the Trüper User Utility and the special shading paper that is provided with the scanner.

When Is Shading Adjustment Required?

Perform shading adjustment when the density of the scanned images is uneven and the image displays perpendicular lines, when colors in some parts of the scanned image are extremely different from what is expected, or when the image quality fails to be improved even after cleaning inside the scanner.

Shading Adjustment Procedure

Preparation: Before performing shading adjustment, thoroughly clean the scanner's drive rollers, reference plates and ADF glass areas. If shading adjustment is carried out while these parts are still dirty, it will not be possible to eliminate the lines that form on the scanned images. Follow the cleaning procedures beginning on [page 83](#).

1 Click the  icon to open the Trüper User Utility.

2 Click the **User Shading** button on the main menu and follow the instructions. See also [“User Shading” on page 103](#).

Note

If the scanned images are still lined after shading adjustment has been performed and if these lines are not eliminated even after the ADF glass areas have been cleaned, it means that the shading has not been compensated properly. Clean the parts again and perform the shading adjustment procedure again.

Additional shading paper for shading adjustment is available from the Böwe Bell + Howell Scanning Essentials online store at <http://webstore.bbhscanners.com> or from the reseller where you purchased the Trüper scanner. See also the [“Consumable Parts List” on page 13](#).

Appendix 4—Adding Memory

The scanner package includes 64 MB of base memory installed on the interface board. Some scanning work may require additional memory depending on variables such as the size of the sheets to be scanned and the image resolution settings. For example, two-sided scanning of larger sheet sizes such as A3 or color scanning at a resolution of 600 DPI may require additional memory.

To add memory, please read the following information and follow the installation procedures.

Recommended DIMM Specifications

The following DIMM (Dual Inline Memory Module) specifications are recommended for the Trüper scanner:

- JEDEC-Standard 168 pin, dual in-line memory module (DIMM)
- Nonbuffered
- Single +3.3V±0.3V power supply
- Frequency/CAS Latency: 100MHz/CL=2, 133MHz/CL=2, 133MHz/CL=3
- A single 64MB, 128MB, 256MB, or 512MB module may be added

The following DIMM brands and modules have been evaluated and approved for use with this scanner:

- EDGE 128MB Module
- EDGE 256MB Module
- EDGE 512MB Module
- Kingston 128MB Module
- Kingston 256MB Module
- Kingston 512MB Module

Installing a DIMM Module

Removing the Interface Board

- 1** Press the power switch to the OFF position.
- 2** Disconnect the power cord from the electrical outlet and disconnect the computer interface cable.

- 3** Remove the two (2) retaining screws from the interface board. Keep the screws because they are needed to reinstall the interface board.

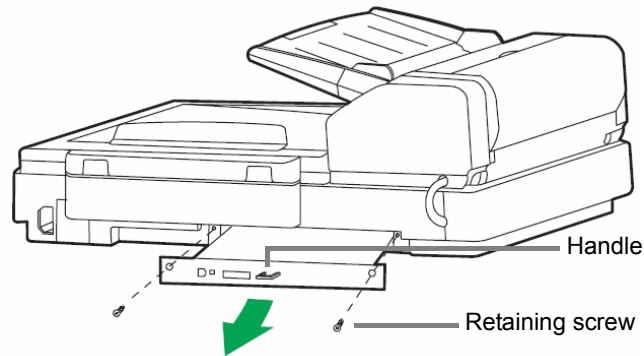

- 4** Remove the interface board by pulling on the handle that is built into the board.



Caution

Do not place your hand inside the unit.

Installing a DIMM Module on the Interface Board

Insert the DIMM module into the module connector on the interface board. Insert the module at an angle as shown in the diagram. Push the module until it clicks into place and the white tabs on the module connector close around the DIMM.

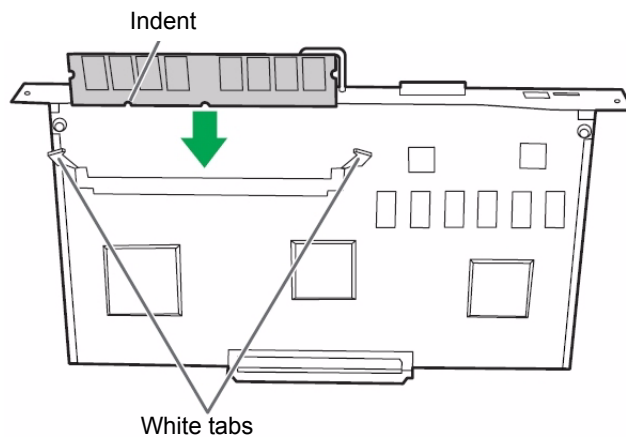

Be sure that the indent on the DIMM module is to the left side when you insert the DIMM, as shown in the view in the diagram. If the indent is not in this position, the DIMM module will not be inserted properly.

To remove the DIMM module, pull the white tabs at both sides of the module connector to release the DIMM module, then carefully pull out the module.

Re-installing the Interface Board

- 1** Insert the interface board into the unit. Guide the board into place along the rails located inside the scanner. Push the board in firmly until it locks into place.

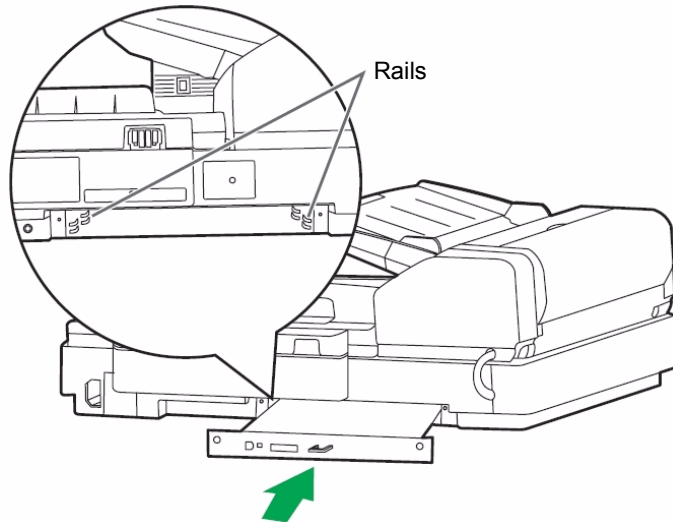

- 2** Confirm that the interface board is fully inserted and firmly locked in place, then secure the interface board with the two (2) retaining screws.

Index

A

- AC input • 28
- Adding Memory • 142
- Additional Contents • 11
- Additional Features • 11
- ADF Glass • 87
- Adjusting the Printing Position • 127
- After Clean Roller • 106
- After Replace Roller • 106
- Auto Color Detect • 12
- Auto Orientation • 12
- Automatic • 118
- Automatic Document Feed (ADF) mode • 118
- Automatic Document Feeder (ADF) • 10
 - Clearing paper Jams • 59
 - Document is not properly scanned • 54
 - Document Size • 10
 - Guidelines • 52
 - Jams • 54
 - Loading landscape • 58
 - Loading portrait • 57
 - Paper Specifications • 10
 - Paper Thickness • 10
 - Paper Weight • 10
 - Removing Jams from Exit Path • 59
 - Removing paper jams • 59
 - Resolution • 10
 - Types of document to avoid • 54
 - Using • 55
- Automatic Document Feeding (Default Mode) • 64

B

- Background Saturation • 12
- Bar Code Recognition • 12
- Blank Page Deletion • 12
- Blower • 26
- Bundled Software • 11

C

- Carriage • 121
- CD-ROM
 - Handling • 23

- Changing the Background Color • 74
- Changing the Background Color Reference Plates • 74
- Changing the Background Color with the Flatbed Sheet • 76
- Check Version Information • 108
- Checklist • 25
- Clean Imprinter • 102
- Cleaning
 - Background Color Reference Plates • 87
 - Drive Rollers • 83, 85
 - Feed Roller • 81
 - Flatbed Glass • 92
 - Paper Sensor • 89
 - Print Head Manually • 129
 - Print Head with the User Utility • 129
 - Start Sensors • 90
- Clear Counter Buttons • 106
- Close • 107
- Component Identification • 15, 121
 - AC input • 15
 - ADF door • 15
 - ADF door release • 15
 - ADF glass • 16
 - Auto feed selector • 15
 - Back stopper • 15
 - Document cover • 15
 - Document guide • 15
 - Exit door release • 16
 - Exit stopper • 15
 - Exit tray • 15
 - Fan exhaust • 15
 - Feeder • 15
 - Feeder extension tray • 15
 - Feeder tray • 15
 - Flatbed glass • 16
 - Flatbed sheet • 16
 - Imprinter door • 15
 - Power cord • 15
 - Power indicator • 15
 - Power switch • 15
 - Reference plate • 16
 - SCSI connector • 15
 - Top cover • 15
 - USB connector • 15

- Computer interface board • 17
- Computer System Requirements • 13
- Connecting the Scanner • 114
- Connector • 121
- Consumable Parts List • 13
- Consumables Options • 11
- Crop • 118

D

- Daily Duty Cycle • 11
- Deskew • 118
- Detect Double Feed • 68
- Disclaimer • 2
- Document Cover Detector • 92
- Document feed guides • 118
- Document Preparation • 52
- Document Size
 - Flatbed • 10
- Double Feed • 118
- Double Feed Detector • 89
- Double Feed Recovery • 12
- Duplex scanner • 118

E

- Emergency Stop mode • 63
- Ending Sensors • 90
- Endorser • 132
- Environment
 - Operating Temperature and Humidity • 11
- Error Code Display • 101
- Error message • 118
- Exchange position • 130
- Exit door • 118
- Exit Rollers • 85
- Exit stopper • 57
- Exit tray • 118

F

- Feed Modes with the ADF • 64
- Feed Roller Assembly • 118
- Feeder • 118
- Feeder Capacity • 10
- Feeder extension tray • 57

- Feeder Tray
 - Attaching • 27
- Feeder tray • 26, 57
- Flatbed • 106
 - Document Size • 10
 - Resolution • 10
- Flatbed sheet • 118
- Free Rollers • 83, 85
- Front Page, Pre-Scan Imprinter Installation • 120

G

- Glass (ADF glass or flatbed glass) • 118
- Glossary • 118
- Guidelines for Using the ADF • 52

H

- Help • 107

I

- Image Enhancement • 10
- Imprinter • 118, 132
- Imprinter Options • 11
- Initial Setup • 28
- Ink Cartridge
 - Ink Cartridge Life • 131
 - Nozzles • 131
 - Operating environment • 131
 - Storage environment • 131
 - Unusable documents • 131
- Ink cartridge • 121
- Ink cartridge adjusting lever • 121
- Ink Cartridge Installation and Printing
 - Position • 125
- Ink Cartridge Specifications • 131
- Installation • 28
- Installing
 - Imprinter Unit • 121
 - Scanner • 25
 - Software • 28, 34
- Installing a DIMM Module • 142
- Installing a DIMM Module on the Interface
 - Board • 143

Installing the Ink Cartridge • 125
Interface • 10
Interface cable • 118
ISIS • 48

L

LED • 50
 Green • 51
 Green (flashing) • 51
 Orange • 51
 Orange (flashing) • 51
 Red • 51
 Status Indicator • 51

M

Manual Feed Mode • 69
Manual feed selector • 15
Manual Feed Setting • 66
Manual mode • 118
Manuals
 Viewing • 49
Maximum number of sheets • 53
Minimum (Standby) • 10
Minimum Space Requirements • 17
Multicolor Dropout • 12, 134, 135
Multicolor Dropout (MCD) • 134
Multicolor Dropout Utility • 134

O

Operating the Scanner • 50
Operator Maintenance
 Cleaning Inside the Scanner • 79
 Cleaning the Outside of the Scanner • 78
Output Options • 10

P

Paper feed roller • 112
Paper jam • 119
Paper Mode/Buzzer Setting • 102
Paper path • 119
Paper recommendation • 52

Paper transport • 119
Paper weight
 Grams/meters • 53
 Pounds • 53
Part Numbers • 13
Power Consumption
 Maximum • 10
Power cord • 26, 28, 119
Power input • 119
Power Requirements • 10
Power requirements • 23
Power switch • 50
Print head • 129
Printing Position Chart • 127

R

Recommended DIMM Specifications • 142
Reference plates or background reference plates • 119
Re-installing the Interface Board • 144
Removing Ink Cartridge • 130
Removing Paper Jams
 Exit path • 61
Removing the Interface Board • 142
Replacing Consumables • 94
 Paper Feed Roller Module • 94
 Retard Roller Module • 97
Resolution • 119
 Flatbed or ADF • 10
Restoring Shading to the Default • 105
Retard Roller • 81
RGB • 119
Roller Cleaning Paper • 80
Roller cleaning paper • 26
Rollers • 119

S

Safety Precautions • 18, 120, 125
Save Info • 107
Scale • 121
Scanner
 Connecting • 28
 Installation • 28
 Installing • 25
 Operation • 50
 Turning on • 50
 Unpacking • 25, 26

- Scanner Counter • 106
- Scanner Information • 101
- Scanner Size • 10
- Scanner Status • 101
- Scanner Unit • 10
- Scanner Weight • 10
- Scanning Method • 10
- Scanning Mode • 10
- Scanning Speed • 10
- SCSI (Small Computer System Interface) • 119
- SCSI Connection • 111
- SCSI Interface Connection • 114
- Select Scanner(X) • 107
- Separation Roller • 81
- Separation roller • 119
- Shading Adjustment • 105, 141
 - Preparation • 141
 - Procedure • 141
 - Purpose • 141
 - Required • 141
- Shading paper • 26
- Simplex scanner • 119
- Single Color Dropout • 119, 134
- Skew • 119
- Skew Sensors • 90
- Sleep Mode • 10, 102
- Specifications • 10
- Start/Stop Button Operation • 63
- Storage Temperature and Humidity • 11
- System • 106

T

- Trademark Acknowledgments • 4
- Transport system • 119
- Troubleshooting • 109
 - (ADF) • 112
 - Scanner Operations • 111
- Turning on the Scanner • 50

U

- Update All Counter • 106
- USB (Universal Serial Bus) • 119
- USB 2.0 cable • 26
- USB cable • 28

- USB connector • 28
- User Shading • 103
- User Utility • 100
 - Starting • 100
- User Utility Error Codes • 109
 - Fxx • 109
 - U11 • 109
 - U12 • 109
 - U13 • 109
 - U14 • 109
 - U15 • 109
 - U16 • 109
 - U17 • 109
 - U18 • 109
 - U20 • 109
 - U23 • 109
 - U30 • 109
 - U32 • 109
 - U34 • 109
- User Utility Main Dialog Window • 101

V

- VirtualReScan • 48
- VRS • 119

W

- Waiting Sensors • 89

Limited Use License Agreement for User Utility

THIS IS A LEGAL AGREEMENT BETWEEN YOU AND BOWE BELL + HOWELL SCANNERS, L.L.C. CAREFULLY READ ALL THE TERMS AND CONDITIONS OF THIS AGREEMENT PRIOR TO USING THE SOFTWARE PROGRAM. YOUR USE OF THE SOFTWARE PROGRAM INDICATES YOUR ACCEPTANCE OF THESE TERMS AND CONDITIONS. If you do not agree to these terms and conditions, do not use the software program.

1. COPYRIGHT:

Bowe Bell + Howell Scanners L.L.C. has the right to license or has been granted the right to license the enclosed program ("SOFTWARE"), developed and copyrighted by Bowe Bell + Howell Scanners, L.L.C. or its licensor ("Licensor"). You acknowledge that you are receiving only a LIMITED LICENSE TO USE the SOFTWARE and related documentation, if any, and that you shall obtain no title, ownership nor any other rights in or to the SOFTWARE and related documentation, all of which title and rights shall remain with Licensor and Bowe Bell + Howell Scanners, L.L.C.

2. LICENSE:

(1) You have the non-exclusive right to use the one copy of the SOFTWARE on a single computer used by single user. Installation of the SOFTWARE on a network server for the purpose of distribution to one or more other computers shall not be granted in this Agreement.

(2) You may not copy, reproduce, or permit to be copied or reproduced, the SOFTWARE or related documentation for any purpose, except that you may either (a) make a reasonable quantity of copies of the SOFTWARE solely for backup or archival purposes, or (b) transfer the SOFTWARE to a single hard disk, provided that you keep the original solely for backup or archival purposes. All other copies of the SOFTWARE are in violation of this Agreement.

(3) You may not rent or lease the SOFTWARE, but you may transfer your right under this License Agreement on a permanent basis, provided that you transfer this Agreement, all copies of the SOFTWARE, all related documentation and your Bowe Bell + Howell Scanners, L.L.C. product, and the recipient thereof agrees to the terms of this Agreement.

(4) You may not reverse engineer, de-compile or disassemble the SOFTWARE, except that in the European Union and European Free Trade Association you may have the limited right to reverse engineer, de-compile or disassemble the SOFTWARE solely to the extent specifically permitted by the terms and conditions of Article 6 of the European Community's Directive for the Legal Protection of Computer programs, OJL 122/42 (17 May 1991).

(5) You may not use, copy, modify, alter, or transfer the SOFTWARE, or any copy thereof, in whole or in part, except as expressly provided in this Agreement.

3. TERM:

This license is effective until terminated. You may terminate this Agreement at any time by destroying the SOFTWARE and related documentation and all copies thereof. This license will also terminate if you fail to comply with any term or condition of this Agreement. Upon such termination, you agree to destroy all copies of the SOFTWARE and related documentation.

4. LIMITATION OF LIABILITY:

NEITHER BOWE BELL + HOWELL NOR BOWE BELL + HOWELL'S SUPPLIER MAKES OR PASSES ON TO YOU OR OTHER THIRD PARTY, ANY WARRANTY OR REPRESENTATION INCLUDING, BUT NOT LIMITED TO, THE IMPLIED WARRANTY OF MERCHANTABILITY AND FITNESS FOR A PARTICULAR PURPOSE. WITHOUT LIMITING THE GENERALITY OF THE FOREGOING, NEITHER BOWE BELL + HOWELL NOR BOWE BELL + HOWELL'S SUPPLIER WARRANTS THAT THE SOFTWARE WILL BE ERROR-FREE OR THAT IT WILL MEET YOUR REQUIREMENTS. NEITHER BOWE BELL + HOWELL NOR BOWE BELL + HOWELL'S SUPPLIER SHALL BE LIABLE FOR ANY DAMAGE SUFFERED BY YOU INCLUDING, BUT NOT LIMITED TO, CONSEQUENTIAL, INCIDENTAL, SPECIAL OR PUNITIVE DAMAGES. THE ABOVE LIMITATIONS SHALL APPLY REGARDLESS OF THE FORM OF ACTION WHETHER IN CONTRACT, TORT (INCLUDING NEGLIGENCE), STRICT PRODUCT LIABILITY OR OTHERWISE, EVEN IF SUCH PARTY HAS BEEN ADVISED OF THE POSSIBILITY OF SUCH DAMAGES.

Web Site: www.bbhscanners.com

© 2005 Bowe Bell + Howell Scanners, L.L.C.